

Build

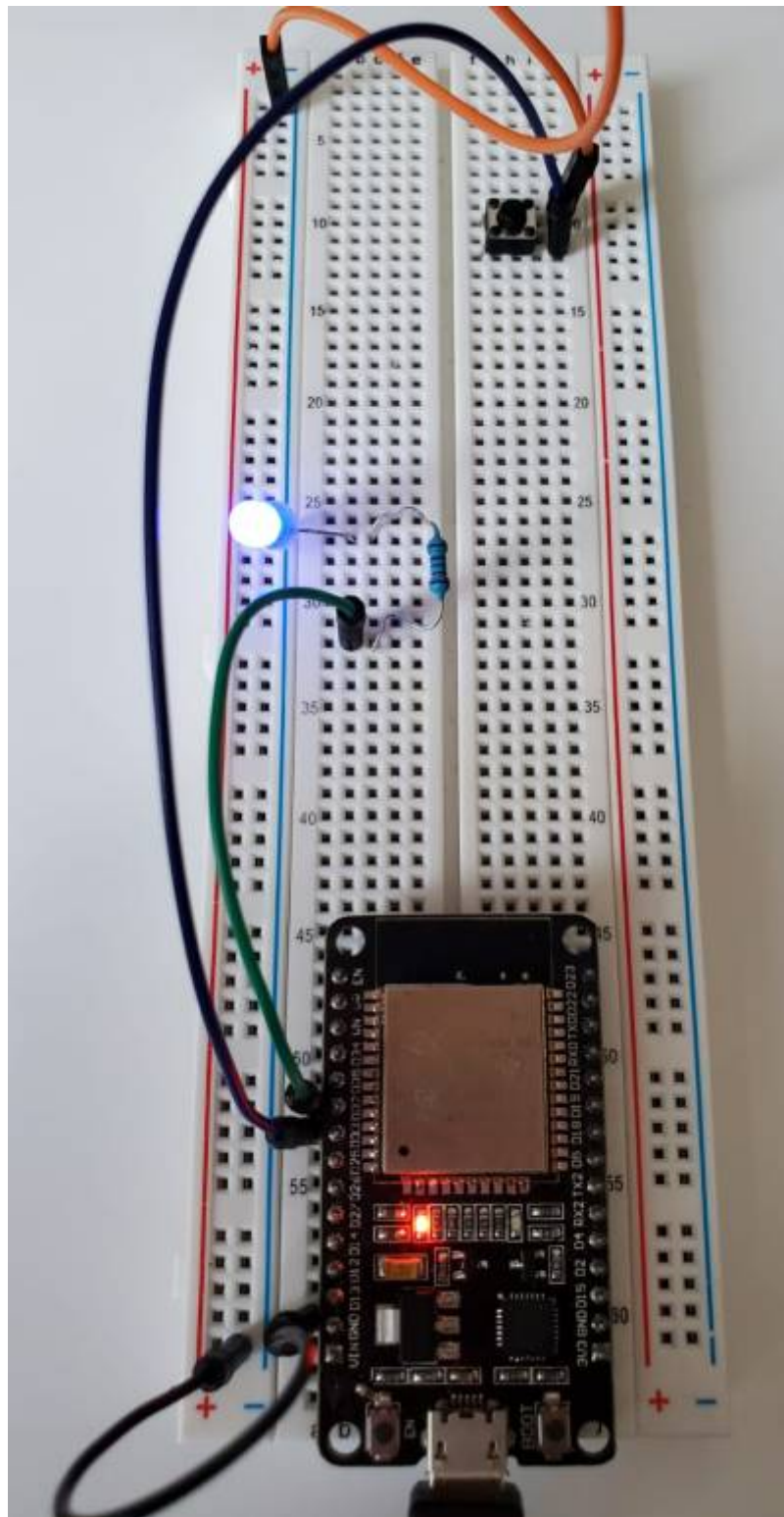

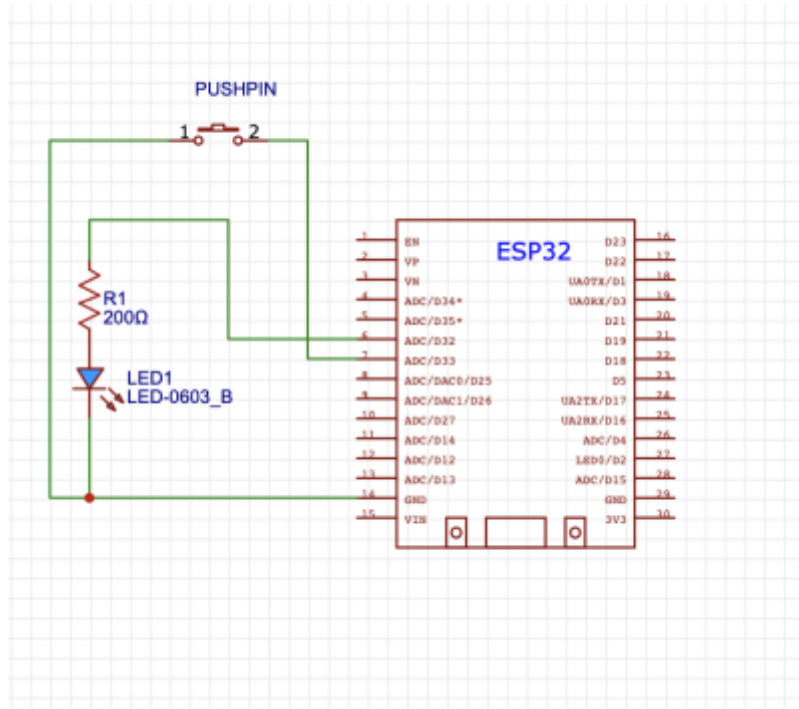

Code

```
<Code c++> #define uS_TO_S_FACTOR 1000000 #define TIME_TO_SLEEP 10
```

```
RTC_DATA_ATTR int bootCount = 0;
```

```
void print_wakeup_reason(){
```

```
    esp_sleep_wakeup_cause_t wakeup_reason;
```

```
    wakeup_reason = esp_sleep_get_wakeup_cause();
```

```
    switch(wakeup_reason)
```

```
    {
        case ESP_SLEEP_WAKEUP_EXT0 : Serial.println("PUSHED BUTTON caused the
system to WAKEUP"); break;
        case ESP_SLEEP_WAKEUP_TIMER : Serial.println("TIMER caused the system to
WAKEUP"); break;
        default : Serial.printf("DeepSleep didn't wake up ESP32:
%d\n",wakeup_reason); break;
    }
```

```
}
```

```
void setup(){
```

```
    Serial.begin(115200);
```

```
    delay(1000);
```

```
    pinMode(32,OUTPUT);
```

```
pinMode(33, INPUT_PULLUP);

for(int i=0;i<5;i++)

{

digitalWrite(32,HIGH);
delay(1000);
digitalWrite(32,LOW);
delay(1000);
}

++bootCount;

Serial.println("Reboot count number: " + String(bootCount));

print_wakeup_reason();

esp_sleep_enable_ext0_wakeup(GPIO_NUM_33,0);

esp_sleep_enable_timer_wakeup(TIME_TO_SLEEP * uS_TO_S_FACTOR);

Serial.println("ESP32 is going into DeepSleep for " + String(TIME_TO_SLEEP) +

" Seconds");

Serial.println("Going to sleep now.....");
delay(1000);
Serial.flush();
esp_deep_sleep_start();

}

</code>
```

Description

Results

```
rst:0x1 (POWERON_RESET),boot:0x13 (SPI_FAST_FLASH_BOOT)
configsip: 0, SPIWP:0xee
clk_drv:0x00,q_drv:0x00,d_drv:0x00,cs0_drv:0x00,hd_drv:0x00,wp_drv:0x00
mode:DIO, clock div:1
load:0x3fff0030,len:1344
load:0x40078000,len:13516
load:0x40080400,len:3604
entry 0x400805f0
Reboot count number: 1
DeepSleep didn't wake up ESP32: 0
ESP32 is going into DeepSleep for 10 Seconds
Going to sleep now.....
ets Jun  8 2016 00:22:57
```

```
rst:0x5 (DEEPSLEEP_RESET),boot:0x13 (SPI_FAST_FLASH_BOOT)
configsip: 0, SPIWP:0xee
clk_drv:0x00,q_drv:0x00,d_drv:0x00,cs0_drv:0x00,hd_drv:0x00,wp_drv:0x00
mode:DIO, clock div:1
load:0x3fff0030,len:1344
load:0x40078000,len:13516
load:0x40080400,len:3604
entry 0x400805f0
Reboot count number: 2
TIMER caused the system to WAKEUP
ESP32 is going into DeepSleep for 10 Seconds
Going to sleep now.....
ets Jun  8 2016 00:22:57
```

```
rst:0x5 (DEEPSLEEP_RESET),boot:0x13 (SPI_FAST_FLASH_BOOT)
configsip: 0, SPIWP:0xee
clk_drv:0x00,q_drv:0x00,d_drv:0x00,cs0_drv:0x00,hd_drv:0x00,wp_drv:0x00
mode:DIO, clock div:1
load:0x3fff0030,len:1344
load:0x40078000,len:13516
load:0x40080400,len:3604
entry 0x400805f0
Reboot count number: 3
PUSHED BUTTON caused the system to WAKEUP
ESP32 is going into DeepSleep for 10 Seconds
Going to sleep now.....
ets Jun  8 2016 00:22:57
```

From:
<https://wiki.eolab.de/> - **HSRW EOLab Wiki**

Permanent link:
<https://wiki.eolab.de/doku.php?id=amc2022:grouph:here&rev=1662738401>

Last update: **2022/09/09 17:46**

