

Build

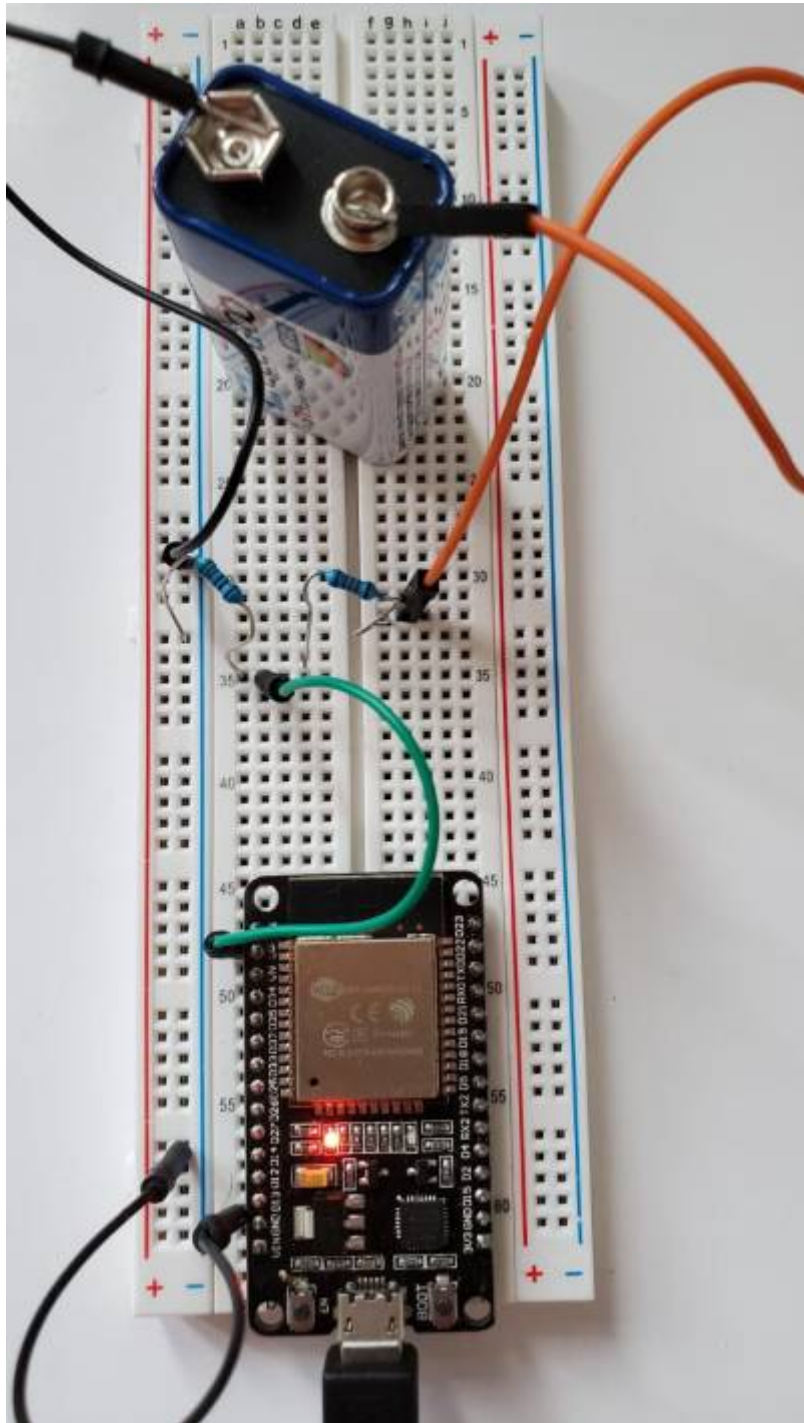

Schematics

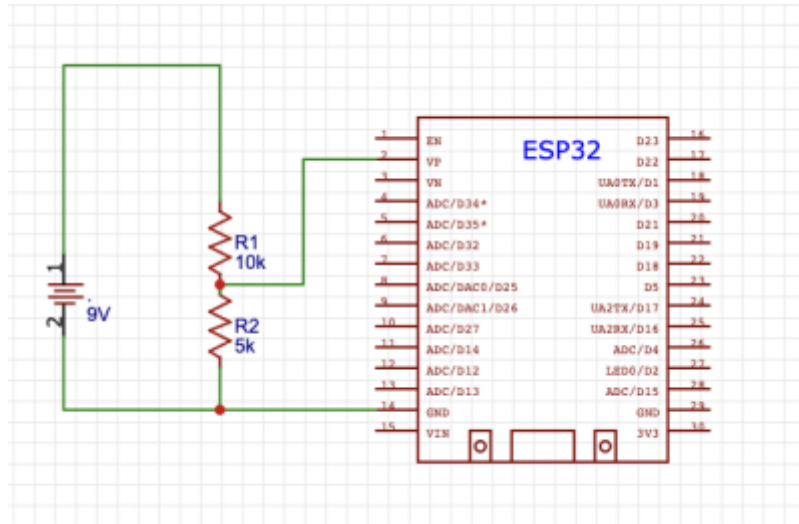

Code & Description

```

*/Reading of voltage is done by the Analog Pin reader.
*/Because the max input voltage on the pins is 3.3 V we cant directly read the 9V battery voltage.

int potPin = A0;           // Analog pin has to be ADC 1, because ADC 2 are
used by wifi and wont work
int potValue;
float voltage =0;         // float because its a decimal number not integer
float battery_percent;

void setup() {

  Serial.begin(115200);

  {

    potValue = analogRead(potPin);
    float voltage = (3.3/4095.0) * potValue * 2.73;

    */Resistors and other components can have a varying number of outputs,
although they are usually minimal
    */additional calibration has to be done in order to get accurate readings
    */We have found that the use of a multimeter will help in determining the
values that will provide best outcomes
    */Because we have different boards, resistors and setups, the final code
could have alterations in the calibrating numbers

    Serial.print("potValue:");
    Serial.print(potValue);

    */While the serial monitor output can be changed, we are more interested is

```

in the overall result which is transmitted

**/to Grafana for easy access*

```
Serial.print(" Voltage:");  
Serial.print(voltage);  
Serial.println("V");
```

battery_percent = mapfloat(voltage, 3.0, 9.0, 0 , 100); // min value cut off at 6V and maximum voltage is 9V

```
if (battery_percent > 100)  
{  
    battery_percent = 100;  
}  
if (battery_percent < 0)  
{  
    battery_percent = 0;  
}
```

```
Serial.print("Battery Percentage = ");  
Serial.println(battery_percent);
```

if (voltage > 7.0 && voltage < 8.2) // THIS VALUES HAVE TO CHANGE ACCORDING TO SOURCE

```
{Serial.print("Low bat"); // USE VOLTMETER TO FIND THE ACCURATE VOLTAGE  
}
```

if (voltage <6.5) //cut-off value is at 6V according to specification , we use 6.5V

```
{Serial.print("Replace Battery");  
}  
delay(1000);
```

```
}  
}
```

```
float mapfloat(float x, float in_min, float in_max, float out_min, float out_max)
```

```
{  
    return (x - in_min) * (out_max - out_min) / (in_max - in_min) + out_min;
```

```

}

void loop()
{

}

// NO LOOP NEEDED,,, ONE VALUE WITH
WARNING SHOULD BE DISPLAYED ON GRAFANA

```

Issues & Characteristics

*The actual voltage will not be 100% accurate because the ADC pins have a non-linear

■ Typical Discharge Curve 6F22

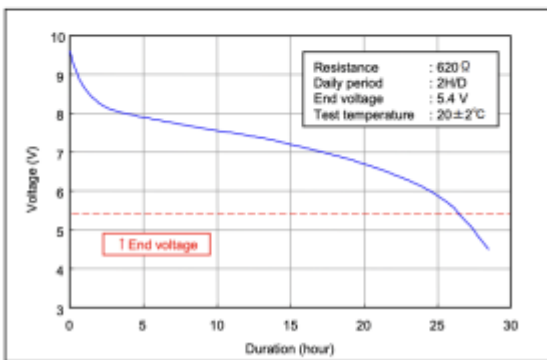
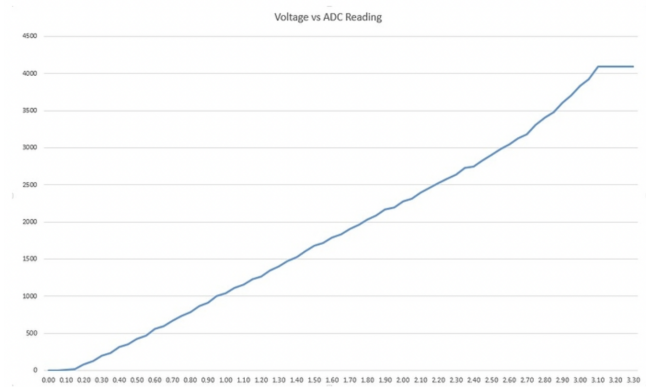
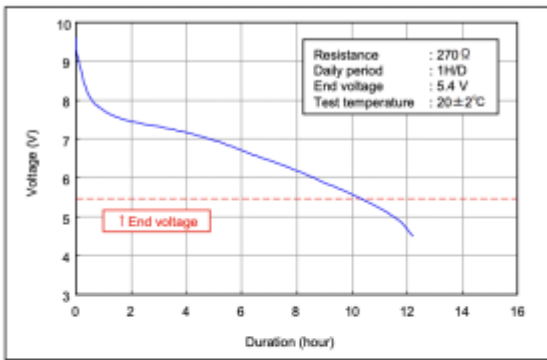

==== Results =====

```

fL@f Z = 04f
f potValue:0 Voltage:0.00V
Battery Percentage = 0.00
Replace Batteryets Jun  8 2016 00:22:57

rst:0x1 (POWERON_RESET),boot:0x13 (SPI_FAST_FLASH_BOOT)
configsip: 0, SPIWP:0xee
clk_drv:0x00,q_drv:0x00,d_drv:0x00,cs0_drv:0x00,hd_drv:0x00,wp_drv:0x00
mode:DIO, clock div:1
load:0x3fff0030,len:1344
load:0x40078000,len:13516
load:0x40080400,len:3604
entry 0x400805f0
potValue:2566 Voltage:5.65V
Battery Percentage = 44.09
Replace Batteryets Jun  8 2016 00:22:57

rst:0x1 (POWERON_RESET),boot:0x13 (SPI_FAST_FLASH_BOOT)
configsip: 0, SPIWP:0xee
clk_drv:0x00,q_drv:0x00,d_drv:0x00,cs0_drv:0x00,hd_drv:0x00,wp_drv:0x00
mode:DIO, clock div:1
load:0x3fff0030,len:1344
load:0x40078000,len:13516
load:0x40080400,len:3604
entry 0x400805f0
potValue:0 Voltage:0.00V
Battery Percentage = 0.00
Replace Batteryets Jun  8 2016 00:22:57

rst:0x1 (POWERON_RESET),boot:0x13 (SPI_FAST_FLASH_BOOT)
configsip: 0, SPIWP:0xee
clk_drv:0x00,q_drv:0x00,d_drv:0x00,cs0_drv:0x00,hd_drv:0x00,wp_drv:0x00
mode:DIO, clock div:1
load:0x3fff0030,len:1344
load:0x40078000,len:13516
load:0x40080400,len:3604
entry 0x400805f0
potValue:2557 Voltage:5.63V
Battery Percentage = 43.76
Replace Battery

```

From:
<https://wiki.eolab.de/> - **HSRW EOLab Wiki**

Permanent link:
<https://wiki.eolab.de/doku.php?id=amc2022:grouph:link&rev=1662760923>

Last update: **2022/09/10 00:02**

