

# Build

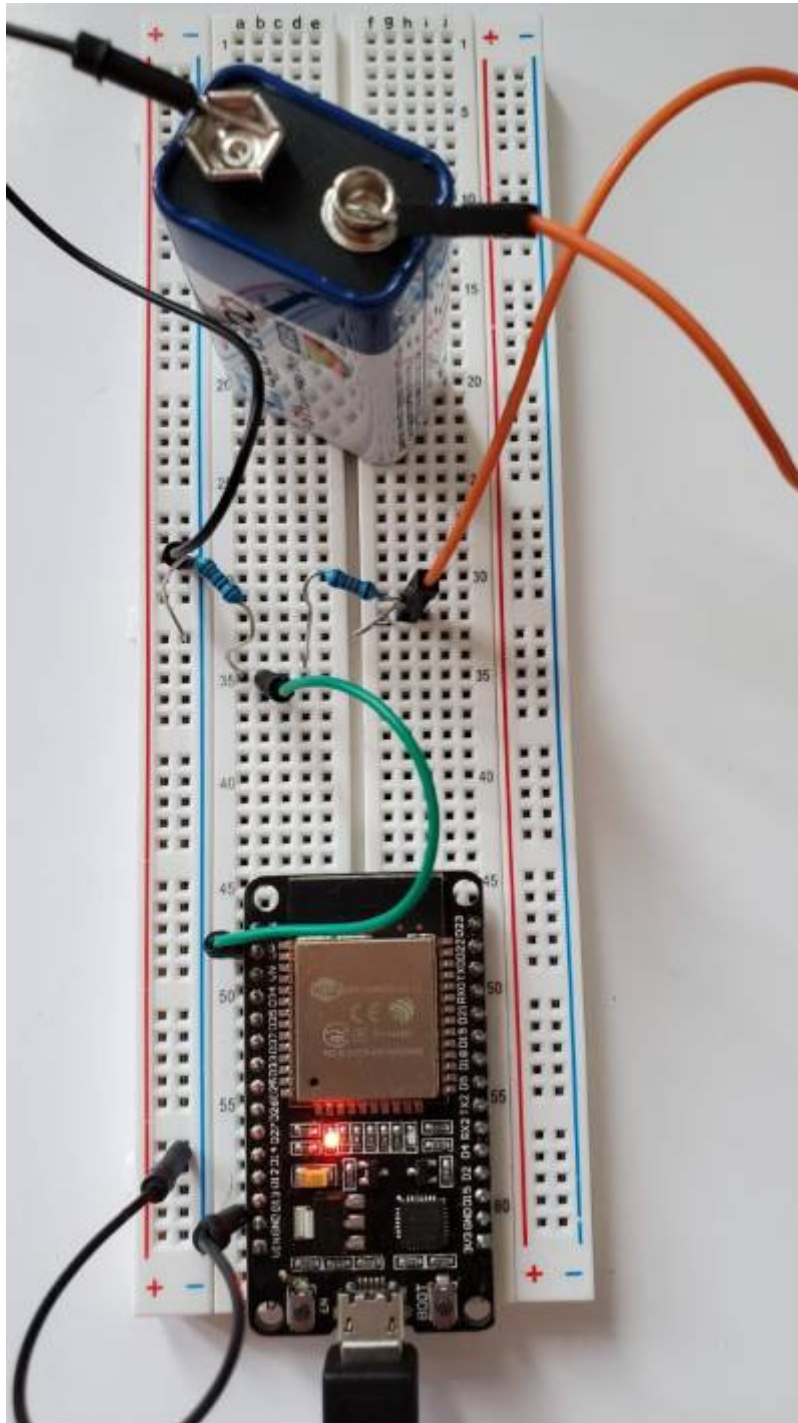

**figure 5.1** Setup showing the connections for battery voltage reading on ESP32

## Schematics

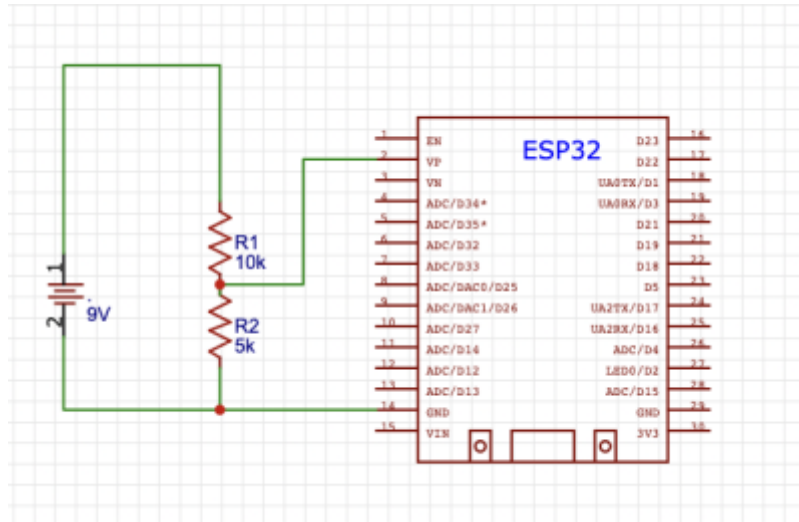

**figure 5.2** Schematic for battery voltage reading

## Code & Description

```

*/Reading of voltage is done by the Analog Pin reader.
*/Because the max input voltage on the pins is 3.3 V we cant directly read the 9V battery voltage.

int potPin = A0;           // Analog pin has to be ADC 1, because ADC 2 are
used by wifi and wont work
int potValue;
float voltage =0;         // float because its a decimal number not integer
float battery_percent;

void setup() {

  Serial.begin(115200);

  {

    potValue = analogRead(potPin);
    float voltage = (3.3/4095.0) * potValue * 2.73;

    */Resistors and other components can have a varying number of outputs,
although they are usually minimal
    */additional calibration has to be done in order to get accurate readings
    */We have found that the use of a multimeter will help in determining the
values that will provide best outcomes
    */Because we have different boards, resistors and setups, the final code
could have alterations in the calibrating numbers

    Serial.print("potValue:");
    Serial.print(potValue);
  }
}

```

```
*/While the serial monitor output can be changed, we are more interested is  
in the overall result which is transmitted  
*/to Grafana for easy access  
  
Serial.print(" Voltage:");  
Serial.print(voltage);  
Serial.println("V");  
  
battery_percent = mapfloat(voltage, 3.0, 9.0, 0 , 100); // min value cut  
off at 6V and maximum voltage is 9V  
  
if (battery_percent > 100)  
{  
    battery_percent = 100;  
}  
if (battery_percent < 0)  
{  
    battery_percent = 0;  
}  
  
*/For the conversion between the actual Analog reading to a percentage we  
use a mapFloat function  
*/It uses the input range from the analog sensor to produce another set of  
useful values  
*/float values will allows to get decimal numbers and a more accurate  
reading  
*/We use a the min voltage value, then max voltage value, and min  
percentage and max percentage  
*/Then we ask the program to give us the corresponding percentage value  
within the parameters  
  
Serial.print("Battery Percentage = ");  
Serial.println(battery_percent);  
  
if (voltage > 7.0 && voltage < 8.2) // THIS VALUES HAVE TO  
CHANGE ACCORDING TO SOURCE  
{Serial.print("Low bat"); // USE VOLTMETER TO FIND  
THE ACCURATE VOLTAGE  
}  
if (voltage <6.5) //cut-off value is at 5.4V  
according to specification , we use 6V  
{Serial.print("Replace Battery");
```

```
}
delay(1000);

*/We have included a notification that will tell us what is going on with
the voltage and overall battery status
*/We include a parameter that will produce 2 warning signs:
*/ LOW BAT means that our battery is within 7 to 8.2V
*/ REPLACE BATTERY means voltage has dropped below 6.5V, number obtained
from data sheet

}
}

float mapfloat(float x, float in_min, float in_max, float out_min, float
out_max)
{
    return (x - in_min) * (out_max - out_min) / (in_max - in_min) + out_min;
}

*/here we include the parameters and equation that will serve as the
backbone for the mapFloat function above.

void loop()
{

}

*/ NO LOOP NEEDED,,, ONE VALUE WITH WARNING SHOULD BE DISPLAYED ON GRAFANA
```

## Issues & Characteristics

The actual voltage will not be 100% accurate because the ADC pins have a non-linear behavior. This means according to the Figure # down below that, above a certain threshold the reading will produce equal inputs, thus we consider that from 3 to 3.3V the battery is at a 100% charge.

Additionally we can see that the discharge behavior of the battery we are using, which is a model 6F22 is a curve that has a specific equation, we could find the curve's equation and use it to better represent the discharge values, however since we plan to upgrade our battery system we purposely used a simpler version in our code to achieve good enough results.

### Typical Discharge Curve 6F22

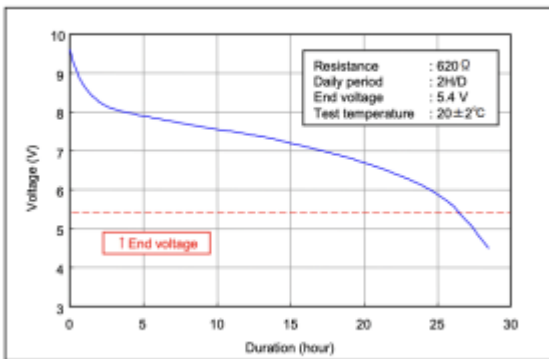
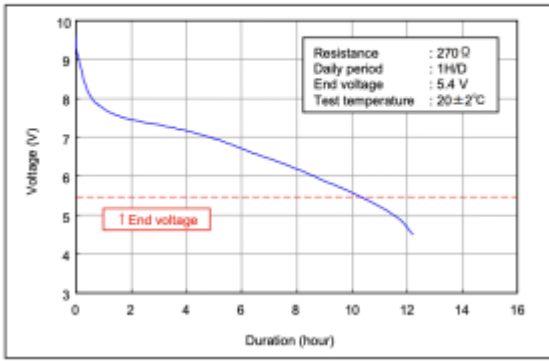

figure 5.3 Graph depicting battery discharge for battery model 6F22 9v  
Source:[https://www.mega-piles.com/im/PANASONIC-6F22-9V-CARBONE-ZINC\\_550.pdf](https://www.mega-piles.com/im/PANASONIC-6F22-9V-CARBONE-ZINC_550.pdf)

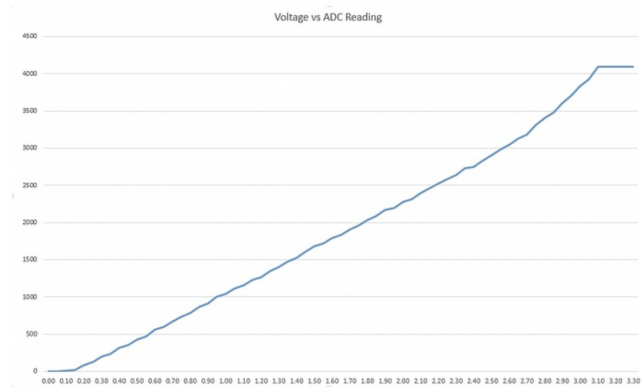

figure 5.4 Graph depicting ADC voltage VS reading behavior for ESP32 micro controller.  
Source:<https://microcontrollerslab.com/adc-esp32-measuring-voltage-example/>

## Results

```
ττL@f Zτ = 04ττ
τ τpotValue:0 Voltage:0.00V
Battery Percentage = 0.00
Replace Batteryets Jun  8 2016 00:22:57

rst:0x1 (POWERON_RESET),boot:0x13 (SPI_FAST_FLASH_BOOT)
configsip: 0, SPIWP:0xee
clk_drv:0x00,q_drv:0x00,d_drv:0x00,cs0_drv:0x00,hd_drv:0x00,wp_drv:0x00
mode:DIO, clock div:1
load:0x3fff0030,len:1344
load:0x40078000,len:13516
load:0x40080400,len:3604
entry 0x400805f0
potValue:2566 Voltage:5.65V
Battery Percentage = 44.09
Replace Batteryets Jun  8 2016 00:22:57

rst:0x1 (POWERON_RESET),boot:0x13 (SPI_FAST_FLASH_BOOT)
configsip: 0, SPIWP:0xee
clk_drv:0x00,q_drv:0x00,d_drv:0x00,cs0_drv:0x00,hd_drv:0x00,wp_drv:0x00
mode:DIO, clock div:1
load:0x3fff0030,len:1344
load:0x40078000,len:13516
load:0x40080400,len:3604
entry 0x400805f0
potValue:0 Voltage:0.00V
Battery Percentage = 0.00
Replace Batteryets Jun  8 2016 00:22:57

rst:0x1 (POWERON_RESET),boot:0x13 (SPI_FAST_FLASH_BOOT)
configsip: 0, SPIWP:0xee
clk_drv:0x00,q_drv:0x00,d_drv:0x00,cs0_drv:0x00,hd_drv:0x00,wp_drv:0x00
mode:DIO, clock div:1
load:0x3fff0030,len:1344
load:0x40078000,len:13516
load:0x40080400,len:3604
entry 0x400805f0
potValue:2557 Voltage:5.63V
Battery Percentage = 43.76
Replace Battery
```

From: <https://wiki.eolab.de/> - **HSRW EOLab Wiki**

Permanent link: <https://wiki.eolab.de/doku.php?id=amc2022:grouph:link&rev=1662763518>

Last update: **2022/09/10 00:45**

