

IoT Workshop at Universidad de La Laguna (ULL) on 2023-10-23

Prerequisites

1. Bring your **own laptops**.
2. Some programming knowledge is an advantage but not a must.
3. We just have **three experimental kits** with ESP32 microcontroller.
Dependent on the number of participants you would have to **form groups**.

Introduction

Internet-of-things (IoT) technologies are a main subject in the maker community for rapid prototyping. They can be used to set up environmental monitoring systems with wireless data transmission and a large variety of sensors. The same technologies can be used to set up easy to use sensor systems for science education in primary schools and beyond.

The workshop at ULL is meant to give some first insights into the IoT technology capabilities to educators of primary school teachers.

For practical reasons we use the **WEMOS D1 R32 board with ESP32** in Arduino UNO form factor. The ESP32 microcontroller provides wireless data transmission by WiFi as well as Bluetooth. We chose the D1 R32 board because it was available at the shop **Faro Electronica La Laguna**.

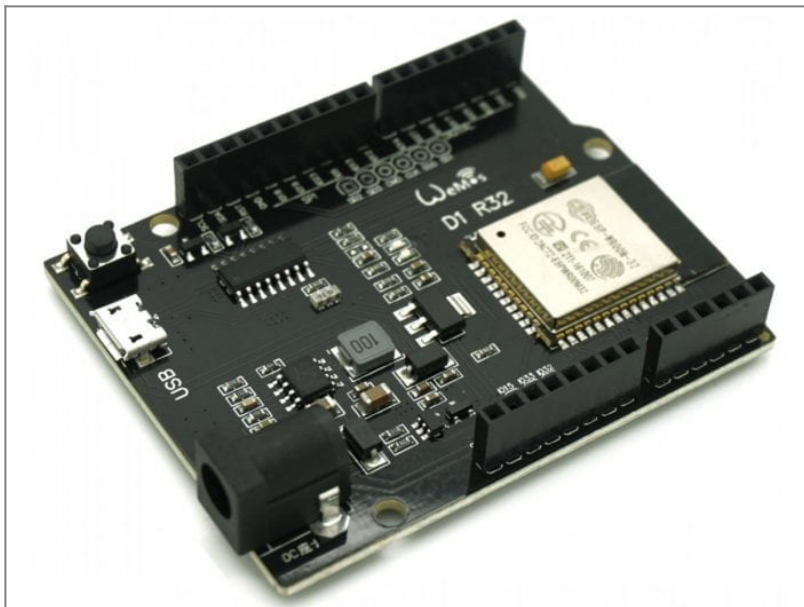

WEMOS D1 R32 (ESP32) microcontroller board.

Source: [Design Tech Auckland](https://www.design-tech.co.nz/)

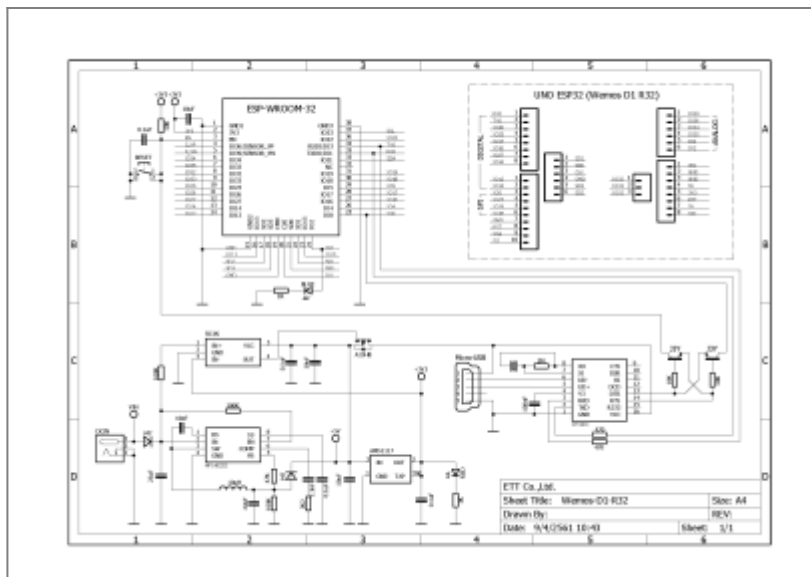

WEMOS D1 R32 (ESP32) SCHEMATIC.
 Click to enlarge.

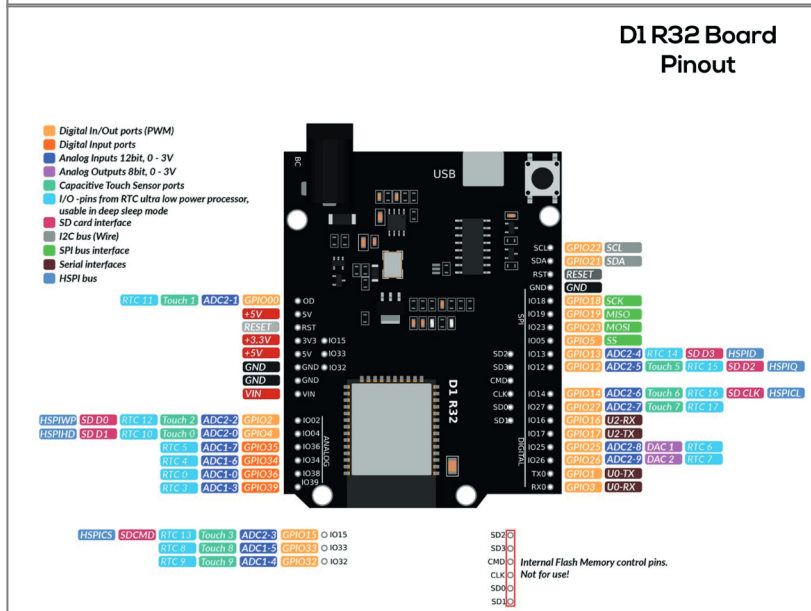

WEMOS D1 R32 (ESP32) PINOUT.
 Click to enlarge.

Installation

1. Install the latest Arduino IDE from [arduino.cc](https://www.arduino.cc) on your computer

Download and follow the instructions from here: <https://www.arduino.cc/en/software>

2. Install the latest ESP32 package to extend the Arduino IDE for ESP32

Follow the instructions here:

<https://docs.espressif.com/projects/arduino-esp32/en/latest/installing.html>

Use the stable(!) release of the ESP32 board repository list to populate the Arduino IDE board manager:

https://espressif.github.io/arduino-esp32/package_esp32_index.json

3. Install the USB-to-Serial Driver for the chip CH341

The installation of the Chinese USB chip driver is a bit scary but safe. Download the zip archive CH341SER.ZIP from here:

https://www.wch-ic.com/downloads/CH341SER_ZIP.html

and follow the instructions.

4. Choose the WEMOS D1 R32 board

Plug in the USB cable of the board into your computer.

Click on the “select board” drop down edit box. On the bottom of the dropdown list click on “select other board and port”.

On the left window pane (left section) search for WEMOS D1 R32 and select this as your board.

On the right window pane (right section) you should see a list of ports one of which being annotated as USB. Select that. To double check you can unplug and replug the board and observe how the port list changes.

5. Parametrize the Arduino IDE

Increase verbosity, make the system talkative!

Go to File→Preferences and check the “Show verbose output during” →Compile and →Upload box

Programming

On your computer create your **own dedicated Arduino working directory**, on e.g. Windows %userprofile%/Documents/Arduino/myProjects/

Let's go!

1. Blink

This is the “Hello world!” program of Arduino. It lets the built-in LED blink. Most of the common Arduino boards have a general purpose LED on board the user can program. This is a good example to start with to understand the **tool chain of programming → compiling → uploading** as well as the **essential program structure** of any Arduino program.

Choose from the menu **File→Examples→01.Basics→Blink**. This opens a new editor window. **Save a copy** of this file by choosing **File→Save as ...** . Save it in your newly created Arduino working

directory under the name  **myBlink.**

In the Arduino IDE choose the right board and port.

Compile and upload the code by pressing the right arrow “→” in the horizontal green Arduino IDE tool bar (just below the menu items).

Observe the output on the black terminal window in the bottom window pane.

When successful the red LED on the board should blink.

The essentials of the Blink code:

[myBlink.ino](#)

```
// the setup function runs once when you press reset or power the board
void setup() {
  // initialize digital pin LED_BUILTIN as an output.
  pinMode(LED_BUILTIN, OUTPUT);
}

// the loop function runs over and over again forever
void loop() {
  digitalWrite(LED_BUILTIN, HIGH); // turn the LED on (HIGH is the
  voltage level)
  delay(1000); // wait for a second
  digitalWrite(LED_BUILTIN, LOW); // turn the LED off by making the
  voltage LOW
  delay(1000); // wait for a second
}
```

2. AnalogInOutSerial

Choose from the menu **File→Examples→01.Basics→AnalogOutInSerial**. This opens a new editor window. **Save a copy** of this file by choosing **File→Save as ...** . Save it in your newly created Arduino

working directory under the name  **myAnalogOutInSerial.**

```
/*
  Rolf Becker's remarks:
  CAREFUL! Ugly? On the "WEMOS D1 R32 board" the following pin definitions
  are used: A0 = Pin 2 = LED_BUILTIN
  The ADC has 12 bits resolution (0 .. 4095) and not 10 bits (0 .. 1023)
  Go for 115200 baud instead of 9600
  Delay 100 ms instead of 2 ms.
*/

// These constants won't change. They're used to give names to the pins
```

used:

```
//old: const int analogInPin = A0; // Analog input pin that the
potentiometer is attached to
const int analogInPin = A5; // Analog input pin that the potentiometer is
attached to

//old: const int analogOutPin = 9; // Analog output pin that the LED is
attached to
const int analogOutPin = 2; // Analog output pin that the LED is attached
to

int sensorValue = 0; // value read from the pot
int outputValue = 0; // value output to the PWM (analog out)

void setup() {
// initialize serial communications at 9600 bps:
//old: Serial.begin(9600);
  Serial.begin(115200);
}

void loop() {
  // read the analog in value:
  sensorValue = analogRead(analogInPin);

  // map it to the range of the analog out:
  //old: outputValue = map(sensorValue, 0, 1023, 0, 255);
  outputValue = map(sensorValue, 0, 4095, 0, 255);

  // change the analog out value:
  analogWrite(analogOutPin, outputValue);

  // print the results to the Serial Monitor:
  Serial.print("sensor = ");
  Serial.print(sensorValue);
  Serial.print("\t output = ");
  Serial.println(outputValue);

  // wait 2 milliseconds before the next loop for the analog-to-digital
  // converter to settle after the last reading:
  //old: delay(2); // 500 Hz
  delay(100); // 10 Hz
}
```

3. Multi-Tasking

Example from

<https://solectroshop.com/es/content/125-tutorial-para-la-placa-wemos-d1-esp32-r32-wroom-32-wifi-y-bluetooth>

esp32-tasks.ino

```
void setup() {
  Serial.begin(112500);
  pinMode(2, OUTPUT);
  vTaskDelay(1000 / portTICK_PERIOD_MS);
  xTaskCreate(task1, "task1", 2048, NULL, 1, NULL);
  xTaskCreate(task2, "task2", 2048, NULL, 1, NULL);
}
void loop() {
  vTaskDelay(1000 / portTICK_PERIOD_MS);
}
void task1( void * parameter )
{
  while(1) {
    Serial.println("Hello World!");
    vTaskDelay(1000 / portTICK_PERIOD_MS);
  }
}
void task2( void * parameter)
{
  while(1) {
    digitalWrite(2, HIGH);
    vTaskDelay(500 / portTICK_PERIOD_MS);
    digitalWrite(2, LOW);
    vTaskDelay(500 / portTICK_PERIOD_MS);
  }
}
```

4. WiFi Scanner

Select: File → Examples → WiFi → WiFiScan

IoT. MQTT Protocol

[Workshop at UNICAES 2023](#), El Salvador (Harley Lara)

Sources

- <https://docs.espressif.com/projects/arduino-esp32/en/latest/installing.html>
- <https://solectroshop.com/es/modulos-wifi/1755-wemos-d1-esp32-r32-wroom-32-wifi-y-bluetooth.html>
- http://kio4.com/arduino/100_Wemos_ESP32.htm
- <https://www.hackster.io/NYH-workshop/wemos-r32-with-arduino-startup-guide-7bc841>

- <https://github.com/espressif/arduino-esp32>

Wemos R32 with Arduino - Startup Guide! (hackster.io)

- <https://www.hackster.io/NYH-workshop/wemos-r32-with-arduino-startup-guide-7bc841>

Datasheets

- https://www.espressif.com/sites/default/files/documentation/esp32-wroom-32d_esp32-wroom-32u_datasheet_en.pdf

Tutorial: Internet de las cosas!

- http://kio4.com/arduino/100_Wemos_ESP32.htm

Tutorial: DS18B20

- <https://randomnerdtutorials.com/esp32-ds18b20-temperature-arduino-ide/>

Backgroup Information

ESP32 Board Variant WEMOS D1 R32 (aka d1_uno32)

Folder with the board specific description file `pins_arduino.h` defining pin names and other parameters for the previously installed esp32 package version 2.0.14:

- Folder on Windows:
%LOCALAPPDATA%\Arduino15\packages\esp32\hardware\esp32\2.0.14\variants\d1_uno32\
- Folder on Linux: to be done
- Folder on Mac: to be done

The **content** of the `pins_arduino.h` for WEMOS D1 R32:

[wemos_d1_r32_arduino.h](#)

```
#ifndef Pins_Arduino_h
#define Pins_Arduino_h

// Board Pinmap:
// https://www.botnroll.com/en/esp/3639-wemos-d1-r32-w-esp32-uno-r3-pinout.html

#include <stdint.h>
```

```
#define EXTERNAL_NUM_INTERRUPTS 16
#define NUM_DIGITAL_PINS      40
#define NUM_ANALOG_INPUTS    16

#define analogInputToDigitalPin(p)
  (((p)<20)?(analogChannelToDigitalPin(p)):-1)
#define digitalPinToInterrupt(p)  (((p)<40)?(p):-1)
#define digitalPinHasPWM(p)      (p < 34)

static const uint8_t TX = 1;
static const uint8_t RX = 3;

static const uint8_t SDA = 21;
static const uint8_t SCL = 22;

static const uint8_t SS    = 5;
static const uint8_t MOSI = 23;
static const uint8_t MISO = 19;
static const uint8_t SCK  = 18;

static const uint8_t A0 = 2;
static const uint8_t A1 = 4;
static const uint8_t A2 = 35;
static const uint8_t A3 = 34;
static const uint8_t A4 = 36;
static const uint8_t A5 = 39;

static const uint8_t LED_BUILTIN = 2;
#define BUILTIN_LED LED_BUILTIN // backward compatibility
#define LED_BUILTIN LED_BUILTIN

#define PIN_WIRE_SDA SDA // backward compatibility
#define PIN_WIRE_SCL SCL // backward compatibility

static const uint8_t D0 = 3;
static const uint8_t D1 = 1;
static const uint8_t D2 = 26;
static const uint8_t D3 = 25;
static const uint8_t D4 = 17;
static const uint8_t D5 = 16;
static const uint8_t D6 = 27;
static const uint8_t D7 = 14;
static const uint8_t D8 = 12;
static const uint8_t D9 = 13;
static const uint8_t D10 = 5;
static const uint8_t D11 = 23;
static const uint8_t D12 = 19;
static const uint8_t D13 = 18;

#define PIN_SPI_SS  SS // backward compatibility
```

```
#define PIN_SPI_MOSI MOSI // backward compatibility
#define PIN_SPI_MISO MISO // backward compatibility
#define PIN_SPI_SCK SCK // backward compatibility

#define PIN_A0 A0 // backward compatibility

#endif /* Pins_Arduino_h */
```

From:

<https://wiki.eolab.de/> - **HSRW EOLab Wiki**

Permanent link:

<https://wiki.eolab.de/doku.php?id=latinet:ull:start&rev=1698005906>

Last update: **2023/10/22 22:18**

