

Wind Speed Sensor

GROUP 4	WIND
NO.	4035.0000
VERSION / DATE / NAME	08 / 01.2016 / KI



DESCRIPTION

The wind speed sensor type 4035 serves for transmission of electrically measured values of the wind speed. It is designed for operation in meteorology and environmental protection, e.g. automatic weather stations, at airports, on research vessels, at industrial sites, for mobile measuring systems etc..

The instrument's rugged construction and its dust- and water repellent surface, as well as the optional high performance heating enable heavy duty applications like wind energy measurement or operation under severe climatic conditions.

Thanks to various simultaneously usable outputs and further options it is suitable for a wide range of measuring tasks (refer to "ordering code").

MECHANICAL DESIGN AND PRINCIPLE OF OPERATION

The sensor is designed as cup anemometer. Its basic construction is shown on fig. 1. The cup assembly comprises three cups (1), made of polypropylene. The hub (4) and is tightened by means of a self securing nut (2). The shaft (3), made of stainless steel, is guided by two precision ball bearings (5), lubricated by a special oil with negligible change of viscosity within a wide temperature range. The housing consists of an upper (7) and a lower part (8). These parts, as well as the hub, are made of a special coated aluminium alloy, featuring

water repellence and corrosion protection. Sealing between upper and lower part is achieved by means of an O-ring. The pivot (9) at the lower part has a size $\varnothing 34 \times 40$ mm and serves for fastening on a cross arm or similar. At the bottom of the pivot there is a socket (10) and plug (11) for a waterproof cable connection according to standard IP 67. The upper part contains a print plate (12) with a reflection light barrier. By means of chopper wheel (13) on the shaft, this light barrier produces a frequency proportional to the wind speed. The built-in heating, placed in the upper part and controlled by a thermostat, features applications during frost season resp. in cold climate.

FIG. 1: MECHANICAL DESIGN

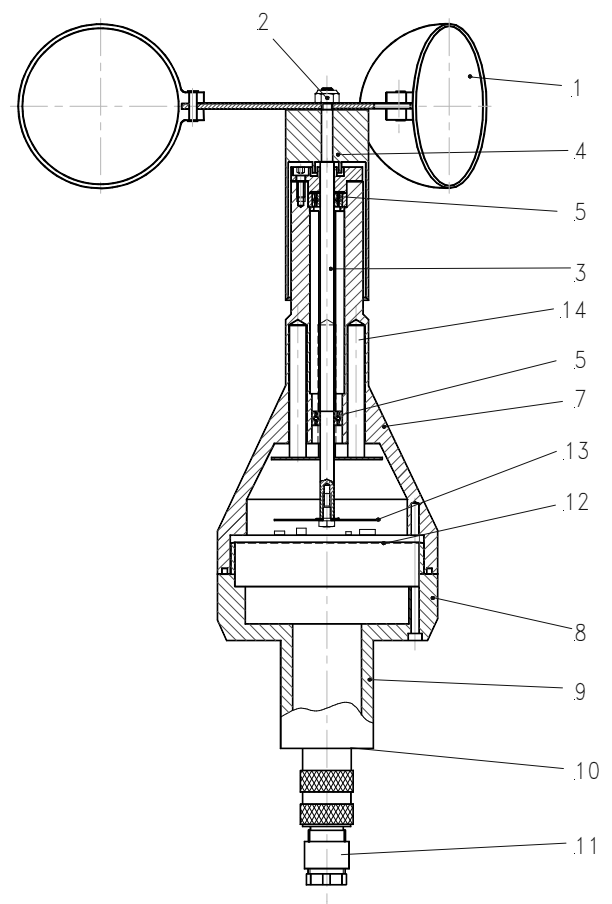



Wind Speed Sensor

GROUP 4	WIND
NO.	4035.0000
VERSION / DATE	08 / 01.2016

ELECTRICAL DESIGN AND PRINCIPLE OF OPERATION

The reflecting wheel, made of special plated aluminium, is equipped with 15 black segments. During rotation these segments pass the light barrier and create a sequence of reflection and absorption pulses, in a frequency proportional to the wind speed. Due to precise adjustment of the cup assembly radius there is an exact relation between rotational speed and windrun; the corresponding windrun to one rotation is 1.5 m. As there are 15 segments on the rotating wheel a resolution of $1.5/15 = 0.1$ m windrun results and the corresponding frequency output to a measuring range 0...70 m/s is 0...700 Hz. The subsequent electronic circuitry converts this signal to a digital output, resp. further analogue outputs (refer to "Technical Data").

CONSTRUCTION OF THE HEATING

The heating consists of a power transistor, controlled by a separate circuitry with temperature sensor.

The high performance heating versions are equipped with 4 cylindrical heaters (14) with 60 W max. heating power.

For further signal processing, such as averaging etc., refer to product group 1, especially datalogger COMBI-LOG 1022.

TECHNICAL DATA

Measuring range:	0...70 m/s (0...60 m/s with analogue outputs)
Max. load:	100 m/s
Starting threshold:	< 0.3 m/s (standard version) 0.21 m/s (sensitive version)
Response length at v = 5 m/s:	< 2.5 m (standard version) 2.0 m (sensitive version)
Accuracy:	+/-0.5 m/s; from 10 m/s 2% of range
Compliances:	WMO Guide No. 8/7th ed. VDI 3786, T.2, 12/2000 MEASNET

Supply:	Electronics: 4035.0000: 10...30 VDC; < 5 mA at 12 V; 4035.1000: 10...30 VDC; 25...65 mA at 12 V Heating: 10...30 VDC; approx. 7 W High performance heating: 24 VDC; approx. 60 W
----------------	--

OUTPUT

digital:	0...70 m/s = 0...700Hz, Open Collector
-----------------	---

additionally, for version 4035.1---

analogue:	0...60 m/s = 0...1 V 0...60 m/s = 0...20 mA 0...60 m/s = 4...20 mA
------------------	--

Admissible load:	approx. 400 Ω
Admissible ambient temperature:	-25...+80 °C; -40...+80 °C with high performance heating
Protection class:	IP 65, when operated upright
Housing material:	Aluminium alloy
Heating:	controlled by thermostat, max. 7 W
High perf. heating:	max. 60 W
Connection:	12 p., plug and socket, water- and dust proof according to IP 67
Measuring cable:	LiY(C)Y 0.25 mm ² (not included)

DIMENSIONS

Length:	approx. 275 mm
Cup assembly \varnothing:	approx. 224 mm
max. housing-\varnothing:	80 mm
Pivot:	\varnothing 34 x 40 mm
Weight:	approx. 0.685 kg

Technical data are subject to change!



Wind Speed Sensor

GROUP 4	WIND
NO.	4035.0000
VERSION / DATE	08 / 01.2016

ORDERING CODE

Wind speed sensor, Frequency output 0...700 Hz, Open Collector; with built-in heating.	4035.0000
As 4035.0000, but with additional analogue outputs 0...20 mA, 4...20 mA and 0...1 V, corresponding 0...60 m/s.	4035.1000
As 4035.0000, but with high performance heating.	4035.0100
As 4035.1000, but with high performance heating.	4035.1100
Sensitive version: As above mentioned types but with supplement:	----.---1

OPERATING INSTRUCTIONS

INSTALLATION

The wind speed sensor has to be placed at a suitable height (for example 10 m for meteorological measurement of the ground wind). There is a number of tilting masts of different heights from 5 to 15 m available for this purpose. Lattice masts up to 80 m height and various telescopic masts can be supplied (refer to product group 9). In any case it has to be taken care to avoid zones of lee or turbulences!

Before mounting the cup assembly has to be fixed on the shaft of the sensor by means of the nut at the face.

Attention:
Take care that the cup assembly is placed correctly (white spot to be underneath)!

Attention:
Do not mount any wind speed sensors without cup assembly, otherwise (during rain) water could penetrate into the housing of the sensor!

Mounting is possible on a stand with 35 mm internal diameter or on an adapter type 9023 (see sketch, fig.2).

In any case a suitable opening ($\varnothing 35$ mm) for plug connection has to be considered. For mounting on a cross arm a clamp type 9022 can be used (see sketch, fig. 2).

Using both - wind speed and wind direction sensor - a U-shaped cross arm, type 9040, is recommended. Depending on location, the installation of lightning rod, type 9112 or equivalent size, is advisable!

Power- and measuring lines shall be protected by suitable over voltage protection devices!

Installation on top of wind turbines, ship masts or similar structures with tilt motion, vibration or other dynamic force requires a rugged, eventually shock absorbing, suspension construction. In this case, please contact us for further consultancy.

CONNECTION

Connection has to be carried out according to fig. 3.

MAINTENANCE

The wind speed sensor type 4035 operates maintenance-free!

Ball bearings, however, are subject to attrition. Their live time strongly depends on the ambient conditions, such as: average wind speed, pollution, vibration etc.. Therefore an occasional check for plausibility (during low wind speed) is recommended: If a decrease of sensitivity is detected, the shaft / ball bearing assembly will have to be replaced.

In case of remote sites with difficult access conditions, for example high measuring towers or wind turbines, an individual service schedule should be issued, including preventive replacement of the bearings, for example every 2 years.



Wind Speed Sensor

GROUP 4	WIND
NO.	4035.0000
VERSION / DATE	08 / 01.2016

FIG. 2: MOUNTING OPTIONS

(Standard from – stock solutions)

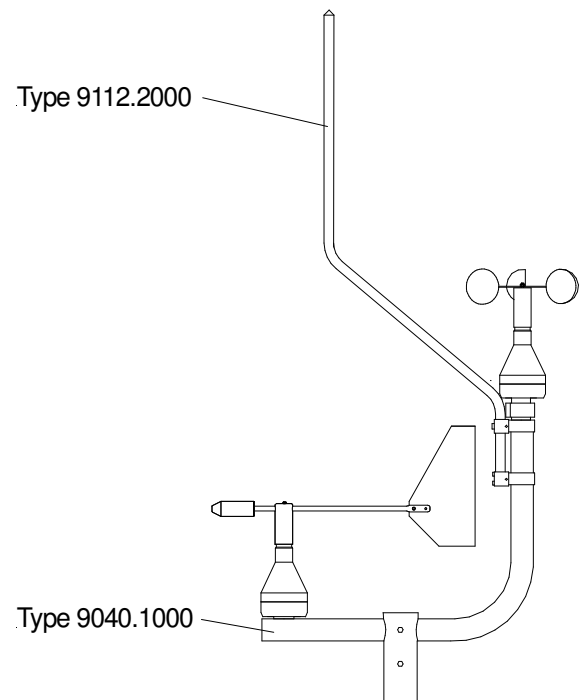
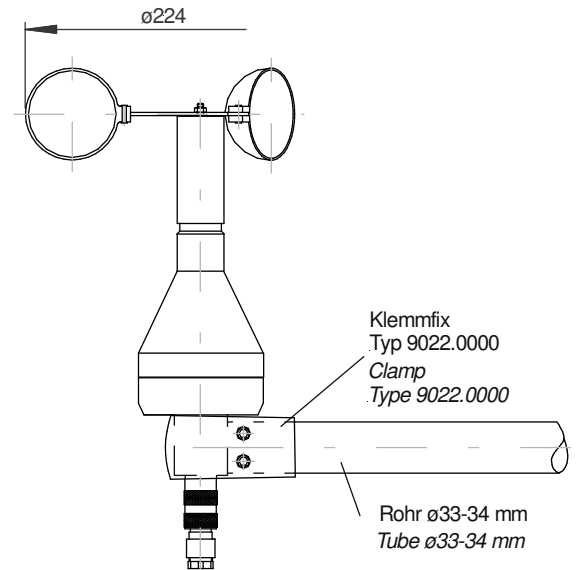
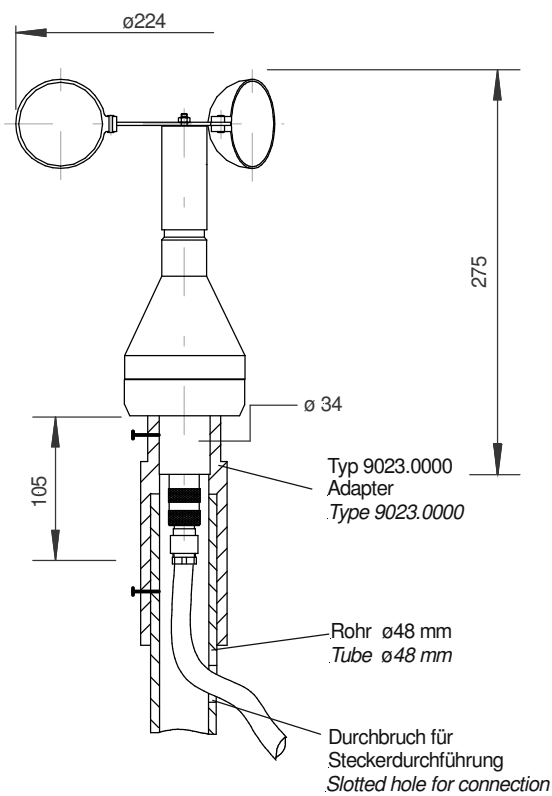

Technical data are subject to change!



Wind Speed Sensor

GROUP 4	WIND
NO.	4035.0000
VERSION / DATE	08 / 01.2016

FIG. 3: BLOCK DIAGRAM / CONNECTION PLAN

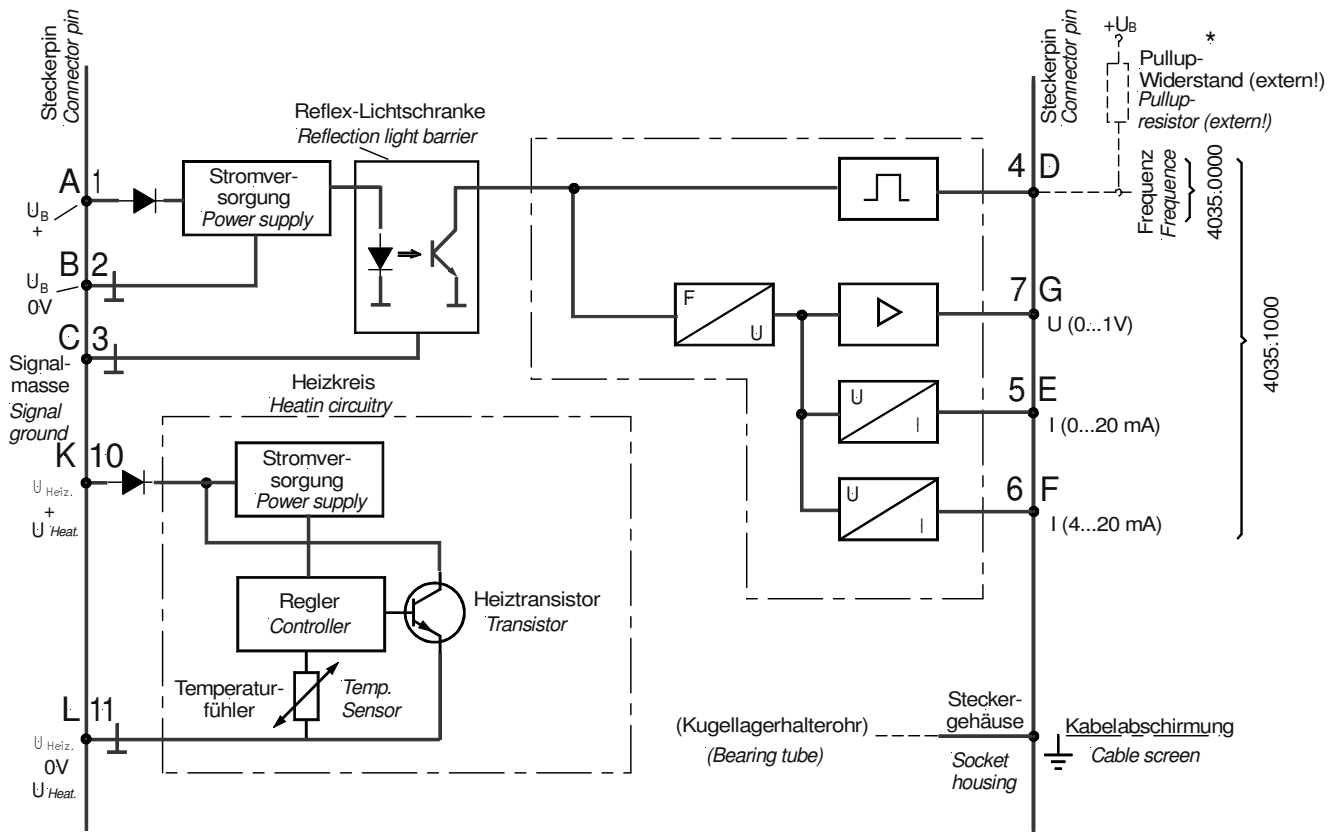

Attention:

When several analogue outputs are used simultaneously, each output requires a separate ground wire to be installed directly close to the sensor.

*Pull-up resistor not included. The maximum value of the resistor depends on the length of the signal cable. Example for cable length up to 100 m : 20 kΩ. In case of connecting the sensor to the COMBILOG 1022 an external pull-up resistor is not necessary.

ATTENTION:

For applications with cable lengths > 5 m between wind speed sensor and indication instrument, it is recommended to use the 0...20 mA output, with 50 Ω shunt, in order to avoid voltage drop due to long distance.

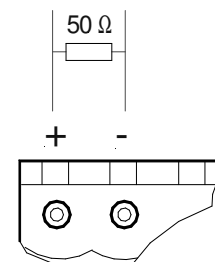

Technical data are subject to change!



Wind Speed Sensor

GROUP 4

WIND

NO.

4035.0000

VERSION / DATE

08 / 01.2016

HANDLING INSTRUCTION, CONNECTOR

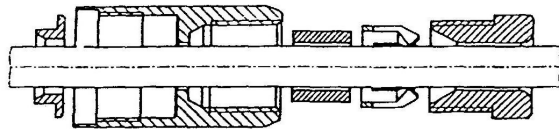

Teile auffädeln
stringing parts

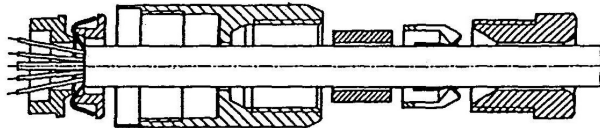

Abisolieren Schirm aufweiten,
Schirmklemmring montieren.
*Stripping, widening of shield,
assembling shield clamping ring.*

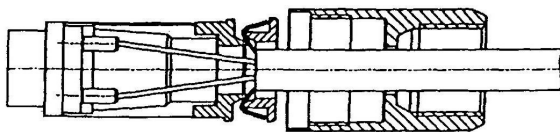

Litze anlöten, Distanzhülse überschnappen,
überstehenden Schirm abschneiden.
*Soldering wire, tripping distance bush,
cutting off projecting shield.*

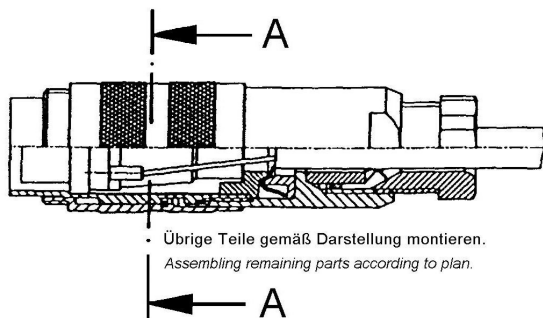

• Übrige Teile gemäß Darstellung montieren.
Assembling remaining parts according to plan.

SECTION A-A,

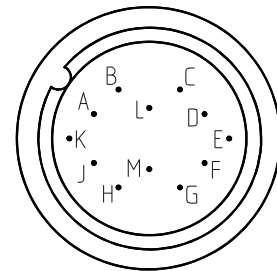

magnified