

Installation manual

IBC TopFix 200

Version 19.01, as of: 05-Apr-2019



Dear customer,

Congratulations, you have chosen an IBC product! Experience for yourself the quality and reliability of the IBC TopFix 200 module mounting system.

To simplify the installation and commissioning of your IBC TopFix 200 mounting system, we have included these detailed installation instructions. They are intended to help you to become familiar with how to fit the frame and the modules quickly.

Please read these instructions carefully before starting the installation. In case of any questions, please get in touch with your IBC SOLAR contact who will be pleased to help.

Sunny greetings
Your IBC SOLAR AG team

Contents

01.	What you will need: tool list.....	4
02.	General information, standards and regulations.....	5
03.	Mounting diagram.....	9
04.	Fitting the various mounting systems.....	12
05.	Fitting carrier rails.....	62
06.	Fitting PV modules	64
07.	Fitting cable clips.....	67
08.	Fitting the two-layer carrier system.....	68
09.	Delta support.....	70
10.	Insertion System	75
11.	IBC FrameFix module frame reinforcements.....	86
12.	Bill of materials.....	88
13.	Appendix.....	103

01. What you will need: tool list

- Cordless screwdriver with a variety of bits (Torx, Phillips, etc.)
- Drill bits (up to Ø 15 mm)
- Pencil
- Tape measure
- Folding rule
- Plumb line
- Open-ended spanner
- Power drill or cordless screwdriver with wrench socket and torque control
- Angle grinder with diamond cutting disc
- Torx screwdriver with T-grip, size TX40, TX25
- Torque wrench

Section “Required tools/auxiliary agents” lists any additional tools required exclusively for our IBC trapezoidal sheet metal assembly system as the mounting system fastener type differs from some other fasteners. For this reason, we have described these in a separate section.

02. General information, standards and regulations

The IBC TopFix 200 mounting system is used for installing your solar modules. The modules are fastened by means of clamps and carrier rails.

The number of components varies according to the size of the system.

Important information:

- Your IBC TopFix 200 mounting system is supplied completely with all accessories.
- Before you begin, please check that all parts are included using the packing list and bill of materials.
- Electrical work must be carried out by qualified electricians only!
- Comply with the processing guidelines and – in individual cases – specific guidelines from the relevant roofing and module manufacturers.
- Condition for the 10-year guarantee to be granted: this applies with the use of IBC SOLAR AG components only. No guarantee claims can be accepted if third-party components are used.
- During the entire assembly time, it must be ensured that at least one copy of the current installation manual is available on the construction site.

General important information and standards relating to dimensioning

The entire photovoltaic (PV) system must be installed in accordance with the generally recognised engineering standards. Comply with accident prevention regulations of the German employer's liability insurance associations (Berufsgenossenschaften), in particular:

- BGV A1 General instructions
- BGV A2 Electrical systems and equipment
- BGV C22 Construction work
- BGV D36 Ladders and steps

Please ensure that installation work takes account of the actual conditions at the installation site and is in accordance with the generally recognised engineering standards. Local regulations must be complied with.

Please observe all regulations and guidelines under public law during planning, erection, operation and maintenance of PV plants connected to grids including the following: EN standards, DIN standards, TAB, accident prevention regulations, the guidelines from the association of property insurers (VDS – fire protection guidelines), the trade guidelines of the German roofing association (Fachregeln des Deutschen Dachdeckerhandwerks) and general guidelines (e.g. timber structures, roofing and roof-sealing works).

Please note in particular (this is not an exhaustive list):

- DIN/VDE 0100, particularly part 712 (erection of power installations with nominal voltage up to 1000V)
- DIN/VDE 0298 (electrical wiring)
- VDI 6012 (distributed energy systems in buildings – photovoltaic)
- DIN/VDE 0126 (solar energy systems for domestic use)
- DIN/VDE 0185 parts 1 to 4 (lightning protection)
- DIN 18338 Roof covering and roof sealing works
- DIN 18451 Scaffolding works
- DIN 18015 Planning and erection of electrical installations in residential buildings
- TAB (utility companies' technical low-voltage grid connection conditions)
- VDEW standard (standards for the connection and parallel operation of independent generation systems on low-voltage grids)
- Information on manufacture, planning and implementation of solar plants from the German Institute of Civil Engineering (DIBt), in the current edition
- DIBt building regulation list, in the current edition
- DIN 4102-1:1998 Fire behaviour of building materials and elements – part 1: building materials; classification, requirements and tests
- DIN EN 13501-1:2010-01 Fire classification of construction products and building elements – part 1: classification using the results from fire behaviour tests on construction products
- EN 1991-1-3 (General actions – snow loads)
- EN 1991-1-4 (General actions – wind loads)
- EN 1993-1-1 Design of steel structures: general rules and rules for buildings
- EN 1995-1-1 Design of timber structures
- EN 1999-1-1 Design of aluminium structures
- General certificate of building approval Z-30.3-6: products, connecting devices and structural components made from stainless steel
- General building authority approval for individual system components
- DIN 4426 Equipment for building maintenance - Safety requirements for workplaces and accesses - Design and construction

- DGUV Information 203-080 - Installation and maintenance of PV systems
- DGUV Information 201-056 - Planning principles of anchor devices on roofs
- Model Building Regulation (MBO) / state building regulations

Solar modules

Solar modules may only be used if they hold the following valid certification:

- IEC 61215/IEC 61646 and protection class II/IEC 61730

Framed solar modules

Please note that the guarantee for the solar modules will be rendered void if modifications are made to the module frames (e.g. by drilling additional holes). In order to comply with warranty conditions, the installation instructions of the respective solar module manufacturer must be strictly observed.

Lightning and overvoltage protection

The lightning and overvoltage protection of the PV system must comply with the current specifications of

- DIN/VDE 0185 parts 1 to 4
- DIN/VDE 0100 part 712
- VdS 2010.

Please refer to the specified directives and standards for detailed information. We generally recommend integrating the mounting system and the module frame into the on-site equipotential bonding and using overvoltage protective equipment.

Equipotential bonding is always required if the solar modules used do not comply with protection class II and/or transformerless inverters are used.

The cross-section of the equipotential bonding conductor must correspond to the cross-section of the DC main cable; however, it must be at least 6mm² (copper).

If the building is equipped with a lightning protection system and the PV generator is not located within the protective area of the interception device, the module frame and the mounting system must be integrated into the external lightning protection system and additional overvoltage protective equipment must be installed.

The electrically conducting connection must have a minimum core size of 16mm² (copper). Please obtain information on the currently applicable, technological standards!



Laying the cables

Starting with the frame installation, several points concerning the direction of power lines and laying of cables should be observed.

- To avoid overvoltage couplings from lightning strikes, the resulting conductor loop must be kept to a minimum.
- Routed cables must not obstruct any potential snow and ice from sliding down.
- Water must not collect around routed cables, ensure continuous water drainage.
- Route cables with maximum possible UV and weather protection.



Dimensioning

Our TopFix 200 mounting system is dimensioned using our very own PV Manager software, used to determine the degree of utilisation and hence the suitability of the components to be mounted on your roof. The software is designed as a planning tool. It does not substitute official, static calculations.

If you do not have the PV Manager available for PV plant dimensioning, please contact your responsible sales representative to determine and dimension the mounting system.



Important!

Any calculations for the roof construction as well as any existing superstructures do not form part of the static calculations as part of the PV substructure dimensioning. A structural engineer must inspect and approve of the increased and rearranged loads caused by the PV plant on site.

03. Mounting diagram

There are various possibilities for the arrangement of the mounting system and the modules on the roof. The most common option is to horizontally assemble type e.g. TF50+ carrier rails and arrange solar modules vertically. For this reason, any further mounting procedures describe such an arrangement.

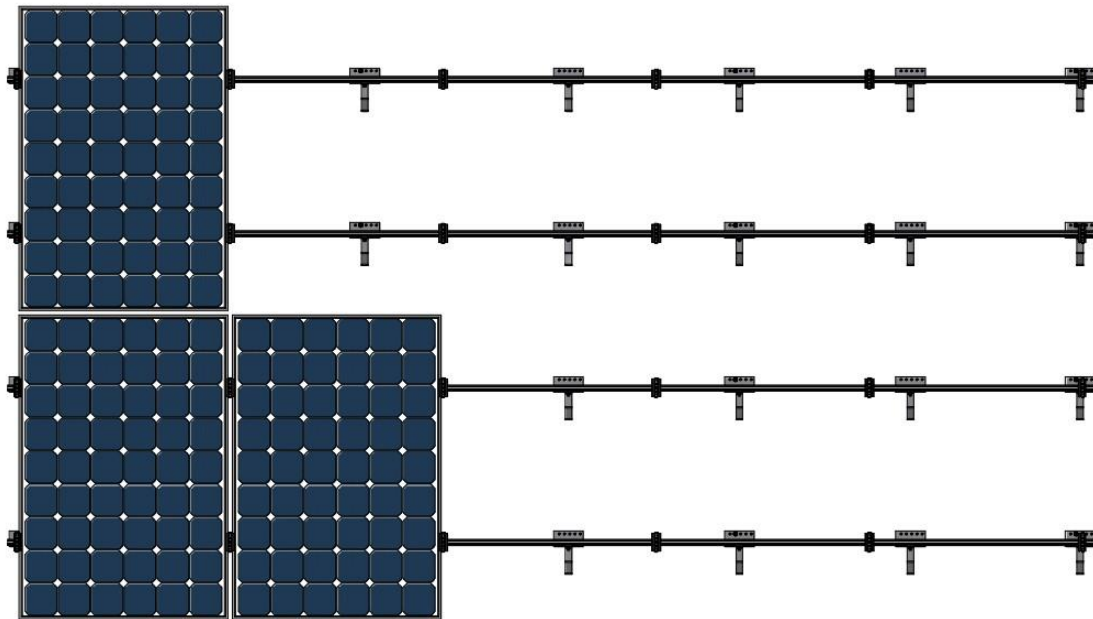


Figure 1: View of the IBC TopFix 200 pitched roof mounting system



Important!

We would like to once again point out that the applicable accident prevention regulations (UVV) must be observed when working on the roof (including DGUV regulation 38).

We have illustrated the layout of the IBC TopFix 200 mounting system to improve transparency:

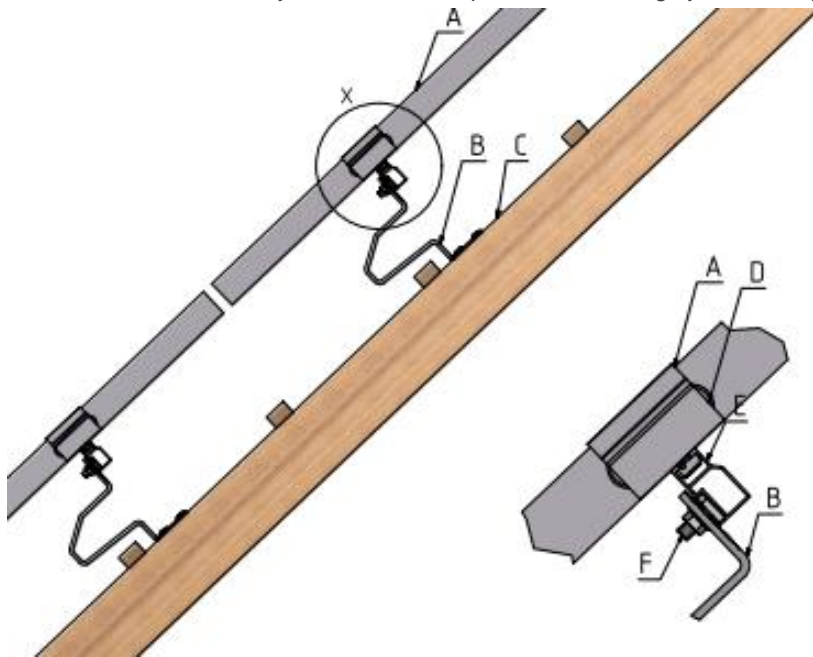


Figure 2: Fastenings for the IBC TopFix 200 pitched roof mounting system

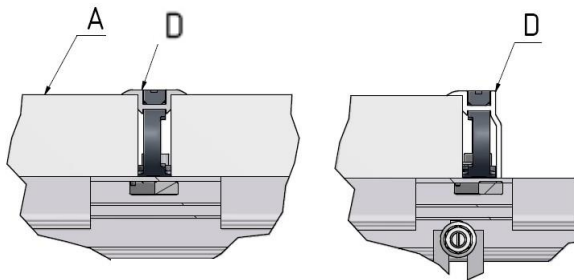


Figure 3: Module fastening of the IBC TopFix 200 pitched roof mounting system

	Description
A	Solar module
B	Roof hooks
C	Rafters
D	module clamp
E	Type TF50+/TF50m/TF60 carrier rail
F	M10x25 A2 T-head screw and M10 A4 locking nut

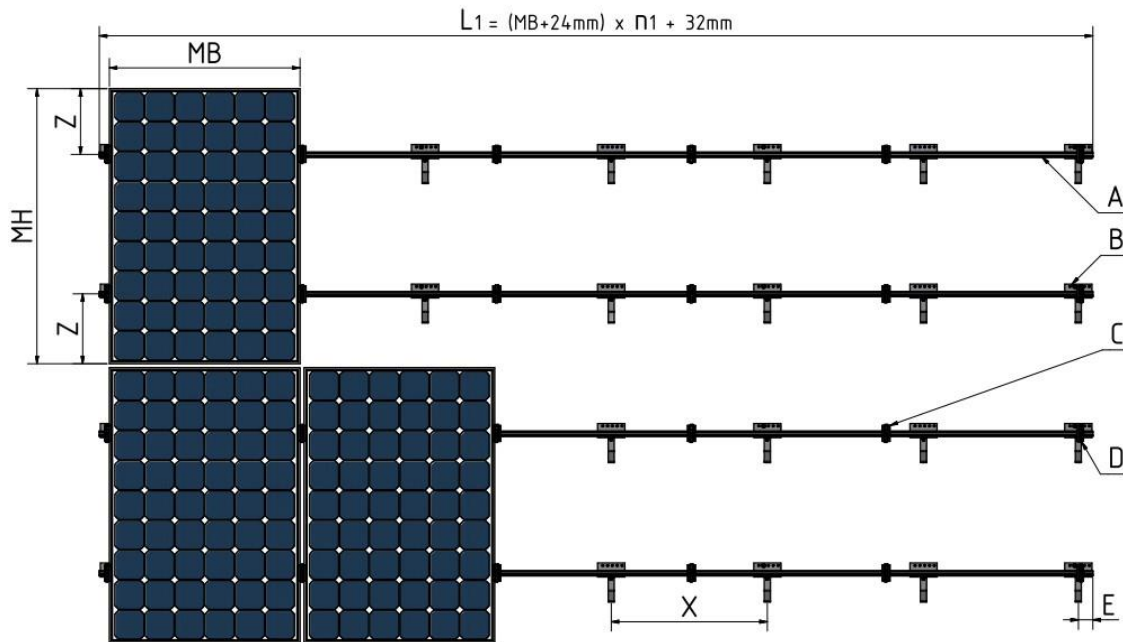


Figure 4: Layout of the IBC TopFix 200 pitched roof mounting system

	Description
$L = (MB + 24\text{ mm}) \times n + 32\text{ mm}$	Carrier rail length = (MB + 24 mm) × number of modules per row + 32 mm
MB	Module width
MH	Module height
A	Type TF50+/TF50m/TF60 carrier rail
B	Roof hooks
C	Middle clamp
D	Outside clamp
E	Max. 400mm
X	X – selected fixing interval (dimensioned using PV Manager software)
Z	Max. ¼ of the module height (please observe module manufacturer specifications)

04. Fitting the various mounting systems



4.1 General dimensioning information

The PV system on your roof is subject to considerable forces caused by snow and, most of all, wind. Improper fastening of the PV system, particularly the modules, may cause significant damage to objects as well as personal injury. For this purpose, it is crucial you observe the following section.

The number of fixing points on the roof is always dependent on the particular design of the roof, building height, roof pitch, the wind and snow load zone and a large number of other factors.

The compatibility of the material pairings between the roof and the PV system must be checked before the installation.

Edges and corner areas must be particularly taken into account as per EN 1991-1-4 (Euro code 1) as increased loads may apply due to wind dynamics, depending on the building type. For more detailed information, please see the graphical indications of fixing points in our PV Manager software. Calculate and verify any specific details according to the applicable standards. In this process, we recommend you consult a structural engineer.

Before starting installation, the existing wooden substructure must be checked for sufficient stability. The wooden substructure must have a service life of more than 20 years. In case of doubt, consult a roofer or joiner and a structural engineer.

As a rule, verify on-site static conditions and whether or not the outer roofing in conjunction with the substructure (steel beams/purlins) is able to bear the additional pressure and dynamic loads of the PV plant.

We shall not assume any system liability for the integrity of the roof as this mainly depends on the quality of mounting or subsequent sealing procedures. The rules of the building trade as well as guidelines and instructions of the roofing manufacturer are to be observed. Mounting system parts must not be treated with additional anti-corrosion protection in normal, atmospheric conditions (corrosivity categories C1-C3 according to EN ISO 12944-2 and surrounding temperatures of -30°C to +50°C). Take additional, suitable anti-corrosion protection measures in the event of other assembly locations (e.g. contact with grit, direct vicinity to the coast, acidic or alkaline environments).

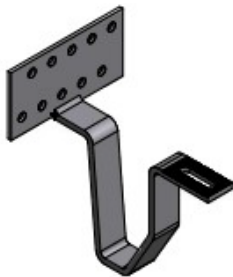
The maximum allowed roof inclination for the mounting system is 75°. It is limited by the permissible inclination of the modules.

Modifications that are not permitted and improper use of our components during assembly and construction shall render and liability and guarantee claims void.

4.2 Fitting the roof hooks

In order to comply with warranty conditions (rain-proofing etc.) we recommend having the roof hooks fitted by a roofing firm. Please also take into account the manufacturer's regulations and specifications for the corresponding roofing, in particular with regard to the use of manufacturer accessories for roofing as well as the overview in section 11 containing data on the rafter dimensions required as per EN 1995-1-1.

Fitting steps:



- Remove the roof tile above the rafter.
- Place the roof hook in the depression in the pantile and align it centrally.
- Screw the roof hook to the rafter using two flat head screws. There is no need to drill holes beforehand.
- Align other roof hooks using a piece of string.
- Reinsert roofing tile.

Figure 5: Roof hook



Important!

Do not use fitted roof hooks as a step ladder, as the pantile below could be damaged by the extreme concentrated load!



Figure 6: Roof hook on the rafter



Figure 7: Fitted roof hook

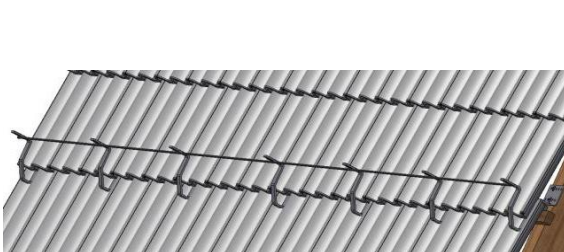


Figure 8: Fitted roof hook



Figure 9: Alignment with piece of string

If the roof hook cannot be fitted as shown above due to the form of the tile or the position of the depression, it is imperative that a roofer is engaged. Changes to roof covering materials (roof tiles, clay tiles, roof panels, cast stone, etc.) may only be made in accordance with the applicable roofing trade regulations and the manufacturer's guidelines.



Important!

The leg of the roof hook lies in the depression in the pantile and must have a clearance of 5mm from the surface of the tile. If necessary an underlay of suitable material should be installed in the space between the rafter and the roof hook's base plate as per Figure 10.

The roofing must not be damaged by loads arising from the fitted roof hooks! If there is a risk of this occurring, additionally install suitable supports to distribute the load. Especially with older tiles, plain tiles and slate roofs and where the installation site is in a high snow load zone, the use of sheet metal supports or tin tiles is recommended. The guidelines of the roofing manufacturer must be observed.

The securing screws in the rafters and the rafters themselves are extremely important for the overall system stress. Chipboard screws are not suitable owing to their smaller head diameter. It must screwing the roof hook to the rafter using two approved 8x100 respectively 6x100 flat head screws from our product range, where no pre-drilling is required. Grease screws to facilitate fastening.

Roof hooks are suitable for most tile types. In individual cases, it may be necessary to remove small pieces from the roof tiles using an angle grinder and suitable cutting disc to ensure that the tile sits flush. The guidelines of the roofing manufacturer must be observed. Particular attention must be paid to the accident prevention regulations when undertaking this work. If applicable, use wooden base blocks on eccentric roof hook connections to distribute the load according to the following figure.

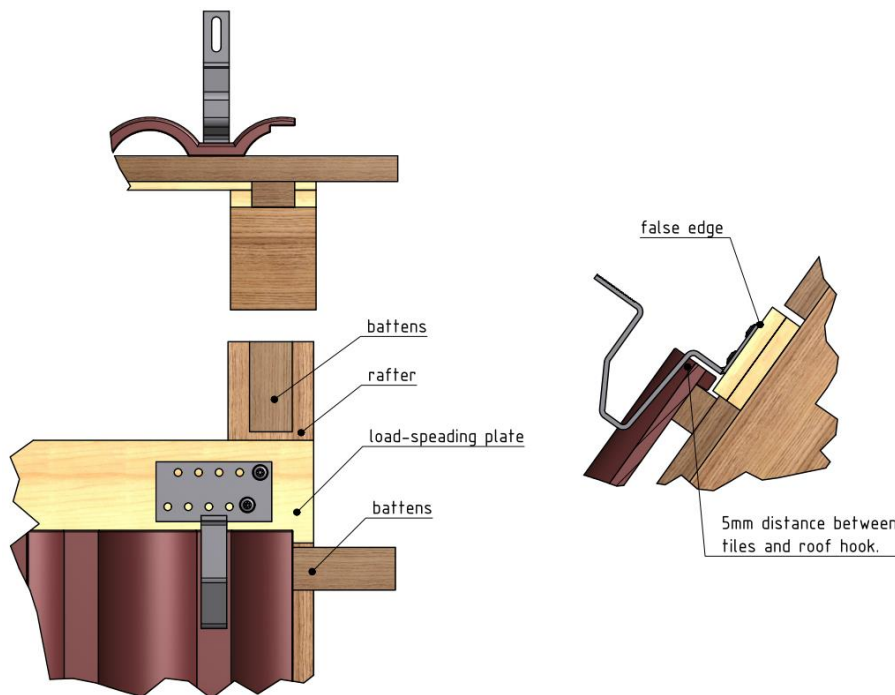


Figure 10: Roof hook load distribution

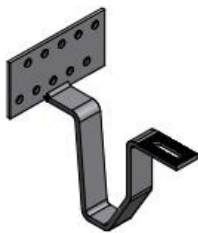
4.3 Roof hook types



Important!

The specifications of the general building approval Z-14.4.-661 for steel roof hooks and Z-14.4.-515 for aluminum roof hooks have to be considered.

4.3.1 "Standard S+" roof hook



Generally the "Standard" S+" roof hook is used.

It is suitable for the most commonly used types of pantiles.

Figure 11: "Standard S+" roof hook

parameters	value		
Material	Stainless steel 1.4301 S275 + S460		
yield strength	Stirrup: $f_{y,k} = 460 \text{ N/mm}^2$ Ground plate: 275 N/mm^2		
Dimensions base plate (length / width / height)	135/ 70/ 4 mm		
Dimensions hook (width / height)	30/ 6 mm		
Drilling holes baseplate	$\varnothing 9 \text{ mm}$		
Drilling holes hook	slot $\varnothing 11 \text{ mm}$, $L=30 \text{ mm}$		
Hook distance from the base plate	45 mm		
weight	0,830 kg		
General construction approval	Z-14.4.-661		
Maximum ch. load / roof hook [kN]	not specified	not specified	not specified
Accessories			
flat head screw 6x100-A2 TX25			
flat head screw 8x100-A2 TX40			
flat head screw 8x140-A2 TX40			
flat head screw ASD 8x240-A2 TX40			
countersunk screw 8x280 TX40			
flat head screw ASD 8x300-A2 TX40			
countersunk screw 8x340 TX40			
connection piece for roof hook profile M10			

Figure 12: Parameters roof hook Standard S+

4.3.2 "Standard S+ 35 mm" roof hooks

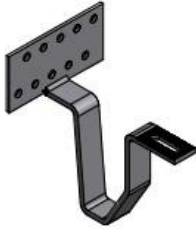


Figure 13: roof hook "Standard S+ 35 mm"

parameters	value		
Material	Stainless steel 1.4301 S275 + S460		
yield strength	Stirrup: $f_{y,k} = 460 \text{ N/mm}^2$ Ground plate: 275 N/mm^2		
Dimensions base plate (length / width / height)	135/ 70/ 4 mm		
Dimensions hook (width / height)	30/ 6 mm		
Drilling holes baseplate	$\varnothing 9 \text{ mm}$		
Drilling holes hook	slot $\varnothing 11 \text{ mm}$, L=30 mm		
Hook distance from the base plate	35 mm		
weight	0,820 kg		
General construction approval	Z-14.4.-661		
Maximum ch. load / roof hook [kN]	not specified	not specified	not specified
Accessories			
flat head screw 6x100-A2 TX25			
flat head screw 8x100-A2 TX40			
flat head screw 8x140-A2 TX40			
flat head screw ASD 8x240-A2 TX40			
countersunk screw 8x280 TX40			
flat head screw ASD 8x300-A2 TX40			
countersunk screw 8x340 TX40			
connection piece for roof hook profile M10			

Figure 14: parameters roof hook "Standard S+ 35 mm"

4.3.3 "Mammut S+" roof hooks

"Mammut S+" roof hooks are used to ensure the safety of the structure under high snow loads. This roof hook provides improved static characteristics compared with the "Standard S+" roof hook. In certain conditions (e.g. low snow load zone), it may be possible to install "Mammut S+" roof hooks only on every second rafter and consequently reduce the number of roof hooks.

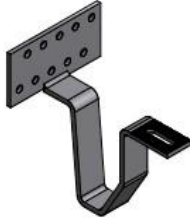
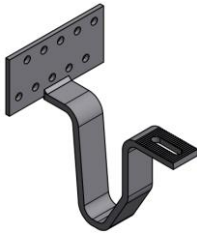


Figure 15: "Mammut S+" roof hook

parameters	value		
Material	Stainless steel 1.4301 S275 + S460		
yield strength	Stirrup: $f_{y,k} = 460 \text{ N/mm}^2$ Ground plate: 275 N/mm^2		
Dimensions base plate (length / width / height)	135/ 70/ 5 mm		
Dimensions hook (width / height)	35/ 6 mm		
Drilling holes baseplate	$\varnothing 9 \text{ mm}$		
Drilling holes hook	slot $\varnothing 11 \text{ mm}$, L=30 mm		
Hook distance from the base plate	45 mm		
weight	0,985 kg		
General construction approval	Z-14.4.-661		
Maximum ch. load / roof hook [kN]	not specified	not specified	not specified
Accessories			
flat head screw 6x100-A2 TX25			
flat head screw 8x100-A2 TX40			
flat head screw 8x140-A2 TX40			
flat head screw ASD 8x240-A2 TX40			
countersunk screw 8x280 TX40			
flat head screw ASD 8x300-A2 TX40			
countersunk screw 8x340 TX40			
connection piece for roof hook profile M10			

Figure 16: parameters roof hook "Mammut S+"

4.3.4 "Mammut XL S+" roof hooks



"Mammut XL S+" roof hooks are used to ensure the safety of the structure under very high snow loads. This roof hook provides improved static characteristics compared with the "Mammut S+" roof hook. In certain conditions (e.g. low snow load zone), it may be possible to install "Mammut XL S+" roof hooks only on every second rafter and consequently reduce the number of roof hooks.

Figure 17: "Mammut XL S+" roof hook

parameters	value		
Material	Stainless steel 1.4301 S275 + S355		
yield strength	Stirrup: $f_{y,k} = 350 \text{ N/mm}^2$ Ground plate: 275 N/mm^2		
Dimensions base plate (length / width / height)	135/ 70/ 5 mm		
Dimensions hook (width / height)	35/ 8 mm		
Drilling holes baseplate	$\varnothing 9 \text{ mm}$		
Drilling holes hook	slot $\varnothing 11 \text{ mm}$, L=30 mm		
Hook distance from the base plate	45 mm		
weight	0,985 kg		
General construction approval	Z-14.4.-661		
Maximum ch. load / roof hook [kN]	not specified	not specified	not specified
Accessories			
flat head screw 6x100-A2 TX25			
flat head screw 8x100-A2 TX40			
flat head screw 8x140-A2 TX40			
flat head screw ASD 8x240-A2 TX40			
countersunk screw 8x280 TX40			
flat head screw ASD 8x300-A2 TX40			
countersunk screw 8x340 TX40			
connection piece for roof hook profile M10			

Figure 18: parameters roof hook "Mammut XL S+"

4.3.5 “Mammut SV+” roof hooks

For vertical installation of the carrier profile in the 1st layer.

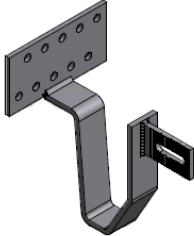


Figure 19: “Mammut SV+” roof hook

parameters	values		
Material	Stainless steel 1.4301 S275 + S460		
yield strength	Stirrup: $f_{y,k} = 460 \text{ N/mm}^2$ Ground plate: 275 N/mm^2		
Dimensions base plate (length / width / height)	135/ 70/ 5 mm		
Dimensions hook (width / height)	35/ 6 mm		
Drilling holes baseplate	$\varnothing 9 \text{ mm}$		
Drilling holes hook	slot $\varnothing 11 \text{ mm}$, L=30 mm		
Hook distance from the base plate	45 mm		
weight	1,02 kg		
General construction approval	Z-14.4.-661		
Maximum ch. load / roof hook [kN]	not specified	not specified	not specified
Accessories			
flat head screw 6x100-A2 TX25			
flat head screw 8x100-A2 TX40			
flat head screw 8x140-A2 TX40			
flat head screw ASD 8x240-A2 TX40			
countersunk screw 8x280 TX40			
flat head screw ASD 8x300-A2 TX40			
countersunk screw 8x340 TX40			
connection piece for roof hook profile M10			

Figure 20: parameters roof hook „Mammut SV+“

4.3.6 “Vario S+” roof hooks

For horizontal and vertical adjustability at the base plate.

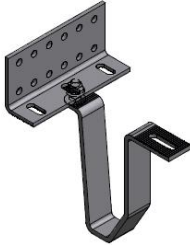


Figure 21: “Vario S+” roof hook

parameters	value		
Material	Stainless steel 1.4301 S460		
yield strength	$f_{y,k} = 460 \text{ N/mm}^2$		
Dimensions base plate (length / width / height)	155/ 75/ 5 mm		
Dimensions hook (width / height)	35/ 6 mm		
Drilling holes baseplate	$\varnothing 9 \text{ mm}$		
Drilling holes hook	slot $\varnothing 11 \text{ mm}$, L=30 mm		
Hook distance from the base plate	42 mm – 55 mm		
Horizontal adjustment at the base plate	$\pm 55,5 \text{ mm}$		
weight	1,355 kg		
General construction approval	Z-14.4.-661		
Maximum ch. load / roof hook [kN]	not specified	not specified	not specified
Incl. 1x coach bolt M10x25 A2 / 70			
Incl. 1x hexagon nut M10 A4 / 70 with locking teeth			
Accessories			
flat head screw 6x100-A2 TX25			
flat head screw 8x100-A2 TX40			
flat head screw 8x140-A2 TX40			
flat head screw ASD 8x240-A2 TX40			
countersunk screw 8x280 TX40			
flat head screw ASD 8x300-A2 TX40			
countersunk screw 8x340 TX40			
connection piece for roof hook profile M10			

Figure 22: parameters roof hook “Vario S+”

4.3.7 "Schiefer S+" roof hooks

Special roof hooks designed for the particular roofing tile shape are used for slate tiles.



Figure 23: "Schiefer S+" slate tile roof hook

parameters	value		
Material	Stainless steel 1.4301 S460		
yield strength	$f_{y,k} = 460 \text{ N/mm}^2$		
Dimensions base plate (length / width / height)	280/ 30/ 6 mm		
Dimensions hook (width / height)	30/ 6 mm		
Drilling holes baseplate	$\varnothing 8,5 \text{ mm}$		
Drilling holes hook	slot $\varnothing 11 \text{ mm}$, L=30 mm		
Hook distance from the base plate	not specified		
weight	0,55 kg		
General construction approval	Z-14.4.-661		
Maximum ch. load / roof hook [kN]	not specified	not specified	not specified
Accessories			
countersunk screw 8x100 A2 TX40			
connection piece for roof hook profile M10			

Figure 24: parameters roof hook "Schiefer S+"

4.3.8 "Plain tile" roof hook

Plain tiles have a different shape from normal roofing tiles. For this reason, a different roof hook type is used.



Figure 25: "Biber S+" plain tile roof hook

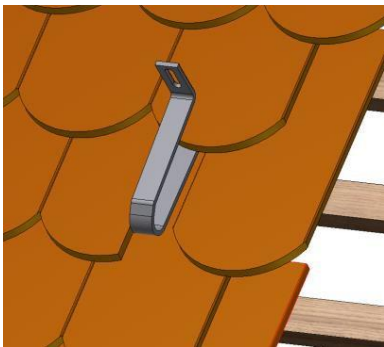


Figure 26: Depression for "Biber S"

parameters	value		
Material	Stainless steel 1.4301 S275 + S460		
yield strength	Stirrup: $f_{y,k} = 460 \text{ N/mm}^2$ Ground plate: 275 N/mm^2		
Dimensions base plate (length / width / height)	135/ 70/ 4 mm		
Dimensions hook (width / height)	30/ 6 mm		
Drilling holes baseplate	$\varnothing 9 \text{ mm}$		
Drilling holes hook	slot $\varnothing 11 \text{ mm}$, L=30 mm		
Hook distance from the base plate	45 mm		
weight	0,970 kg		
General construction approval	Z-14.4.-661		
Maximum ch. load / roof hook [kN]	not specified	not specified	not specified
Accessories			
flat head screw 6x100-A2 TX25			
flat head screw 8x100-A2 TX40			
flat head screw 8x140-A2 TX40			
flat head screw ASD 8x240-A2 TX40			
countersunk screw 8x280 TX40			
flat head screw ASD 8x300-A2 TX40			
countersunk screw 8x340 TX40			
connection piece for roof hook profile M10			

Figure 27: parameters roof hook „Biber S+“

4.3.9 “Alu-Vario S+” roof hooks



4-way adjustable aluminum roof hooks

Figure 28: “Alu-Vario S+” roof hook

parameters	value		
Material	hook: Aluminium EN AC-42100 (DIN EN 1706) base plate: Aluminium EN AC-43000 (DIN EN 1706)		
yield strength	hook: $f_{y,k} = 210 \text{ N/mm}^2$ base plate: 220 N/mm^2		
Dimensions base plate (length / width / height)	100/ 70/ (9) mm		
Dimensions hook (width / height)	35/ 6-8 mm		
Drilling holes baseplate	$\varnothing 7 \text{ mm}$		
Drilling holes hook	slot $\varnothing 9 \text{ mm}$, $L=25 \text{ mm}$		
Hook distance from the base plate	40,6 – 55,6 mm		
Horizontal adjustment at the base plate	70 mm stufenlos		
weight	0,465 kg		
General construction approval	Z-14.4.-515 (in preparation)		
Maximum ch. load / roof hook [kN]	pressure $F_{R,k,-x} = 2,06$	suction $F_{R,k,+x} = 2,15$	shear $F_{R,k,y} = 1,96$
Incl. coach bolt M10x40 A2/70 + locking nut			
Accessories			
Flat head screw 6x100-A2 TX25			
connection piece for roof hook profile M8			

Figure 29: parameters roof hook “Alu-Vario S+”

4.3.10 "Alu-Mammut S+" roof hooks



Figure 30: "Alu-Mammut S+" roof hook

parameters	value		
Material	Aluminium EN AC-42100 (DIN EN 1706)		
yield strength	hook: $f_{y,k} = 210 \text{ N/mm}^2$		
Dimensions base plate (length / width / height)	150/ 63,5/ (12) mm		
Dimensions hook (width / height)	35/ 6-8 mm		
Drilling holes baseplate	$\varnothing 7 \text{ mm}$		
Drilling holes hook	slot $\varnothing 9 \text{ mm}$, L=25 mm		
Hook distance from the base plate	46 mm		
weight	0,465 kg		
General construction approval	Z-14.4.-515		
Maximum ch. load / roof hook [kN]	pressur $F_{R,k,-x} = 3,04$	suction $F_{R,k,+x} = 3,14$	shear $F_{R,k,y} = 3,17$
Accessories			
Flat head screw 6x100-A2 TX25			
connection piece for roof hook profile M8			

Figure 31: parameters roof hook "Alu-Mammut S+"

4.3.11 “Alu-Mammut SV+” roof hooks



For vertical installation of the carrier profile in the 1st layer.

Figure 32: “Alu-Mammut SV+” roof hook

parameters	value		
Material	Aluminium EN AC-42100 (nach DIN EN 1706)		
yield strength	hook: $f_{y,k} = 210 \text{ N/mm}^2$		
Dimensions base plate (length / width / height)	181/ 71/ (12) mm		
Dimensions hook (width / height)	40/ 6-8 mm und 35/ 6-8 mm		
Drilling holes baseplate	$\varnothing 9 \text{ mm}$		
Drilling holes hook	slot $\varnothing 9 \text{ mm}$, L=25 mm		
Hook distance from the base plate	46 mm		
weight	0,500 kg		
General construction approval	Z-14.4.-515		
Maximum ch. load / roof hook [kN]	pressure $F_{R,k,-x} = 2,85$	suction $F_{R,k,+x} = 1,90$	shear $F_{R,k,y} = 2,20$
Accessories			
flat head screw 6x100-A2 TX25			
flat head screw 8x100-A2 TX40			
flat head screw 8x140-A2 TX40			
flat head screw ASD 8x240-A2 TX40			
countersunk screw 8x280 TX40			
flat head screw ASD 8x300-A2 TX40			
countersunk screw 8x340 TX40			
connection piece for roof hook profile M10			

Figure 33: parameters roof hook “Alu-Mammut SV+”

4.4 ASD screws- Mounting on rafter-mounted insulation systems

ASD screws are designed to install roof hooks on roofs with rafter-mounted insulation roofing. They are designed so the insulation is fitted on the rafters, between the layer of rafters and the battens. This insulation layer must not be subjected to static, individual loads, such as roof hooks. The loads from the roof hooks are diverted through the space between the insulation to the load-bearing rafter design using the ASD screws.



Note:

If the roof structure is too high over the rafters for the ASD screws, the roof hooks can also be fixed in the counter battens. By the customer it must be proofed that the corresponding counter battens are fastened to the substructure so that the additional loads can be absorbed and the function of the insulation is not impaired. Observe the minimum edge distances according Figure 166

Select the required screw length according to Figure 34 or using the IBC SOLAR AG PV Manager dimensioning software. It is not required to drill bores before inserting the screws.

Description	Item number	Roof installation height* Max. 235 mm	Roof installation height* Max. 295 mm
ASD flat head screw 8x240-A2	6900300014	X	
ASD flat head screw 8x300-A2	6900300015		X
ASD Countersunk screw 8x280-A2	6900300016	X	
ASD Countersunk screw 8x340-A2	6900300017		X

Figure 34: Overview of screw lengths

*) formwork + insulation + counter batten + integration depth 50 mm

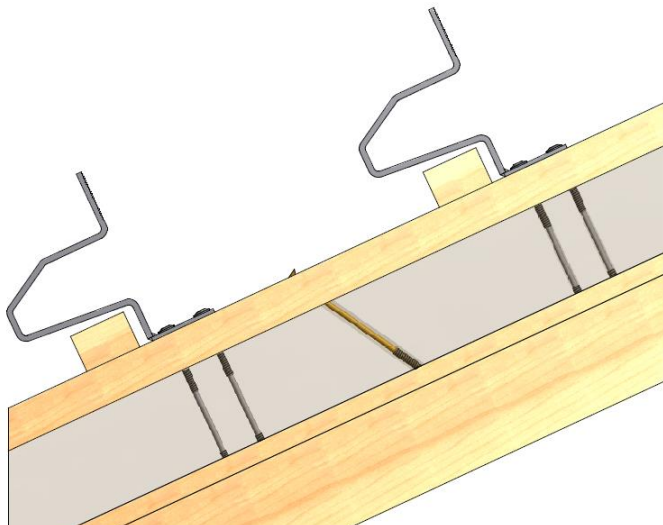


Figure 35: Roof hooks on rafter-mounted insulation systems

- Two ASD flat head screws are required to fasten one roof hook.



Figure 36: Inserting flat head screws

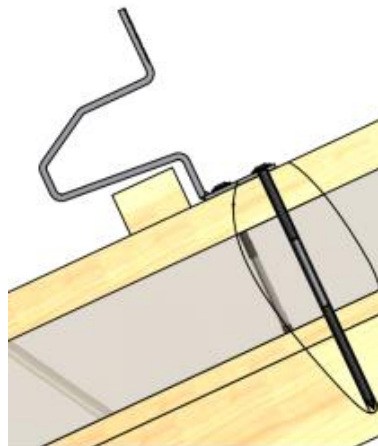


Figure 37: Inserted flat head screws

- Each roof hook connection must additionally be secured by a ASD countersunk screw to absorb sliding forces at an angle of 60°.

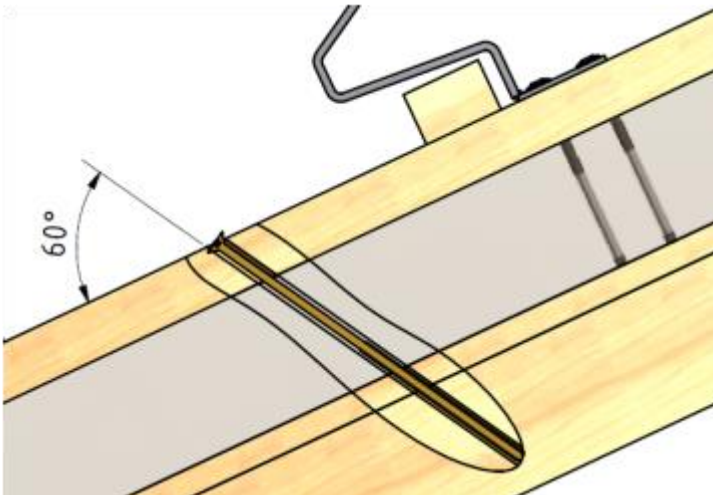


Figure 38: Inserting countersunk screws to absorb sliding forces

4.5 "Mammut Form S+" roof hook

The same conditions and prerequisites as described in section 4.1 apply. "Mammut Form S+" roof hooks are suitable for 30x50mm and 40x60 mm battens.

For available types and colours of tiles, please refer to the IBC Premium Partner portal. Your personal IBC SOLAR AG contact person will of course also be happy to help.



Note:

Superficial damage to the surfaces (scratches) that affect neither static, nor anti-corrosion properties of the roof hook shall not be accepted as a valid reason for complaints.

IBC SOLAR AG recommends to test one "Mammut Form S+" on the available roof tiles as there may be manufacturer-specific dimensions despite the designations being identical (e.g. Tegalit prior to 1996).

Depending on the type of existing roofing, existing roof ties may have to be treated.

4.5.1 Fitting "Mammut Form S+" roof hooks

Step 1:

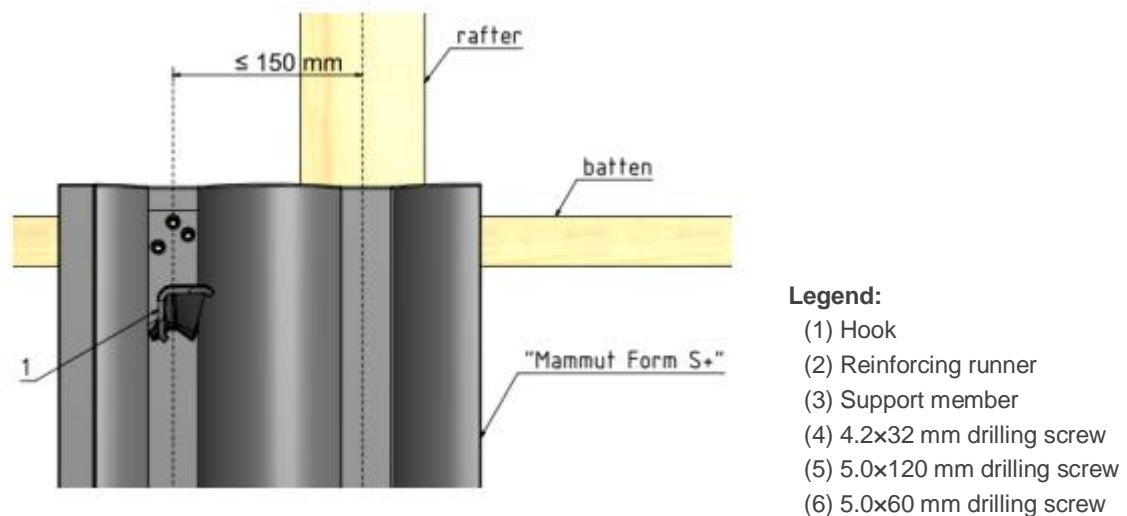


Figure 39: "Mammut Form S+" roof hook

- Specify the roof hook position so that you do not exceed a distance of 150 mm between fastener element (1) and the centre of the rafter.

Step 2:

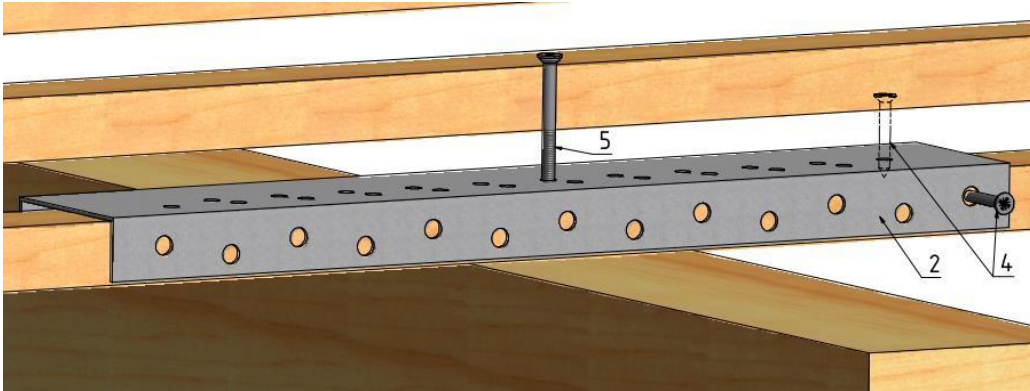


Figure 40: Fastening the batten rail

- Remove roof tile from the specified area
- Horizontally move the reinforcing runner (2) horizontally until the slot on the support member (3) covers the hole of the reinforcing rail. Secure the reinforcing runner using one screw (4) (screw may alternatively be fastened from the top).
- Remove the roof hook once again and fasten the reinforcing runner to the rafter using screws (5).

Step 3:

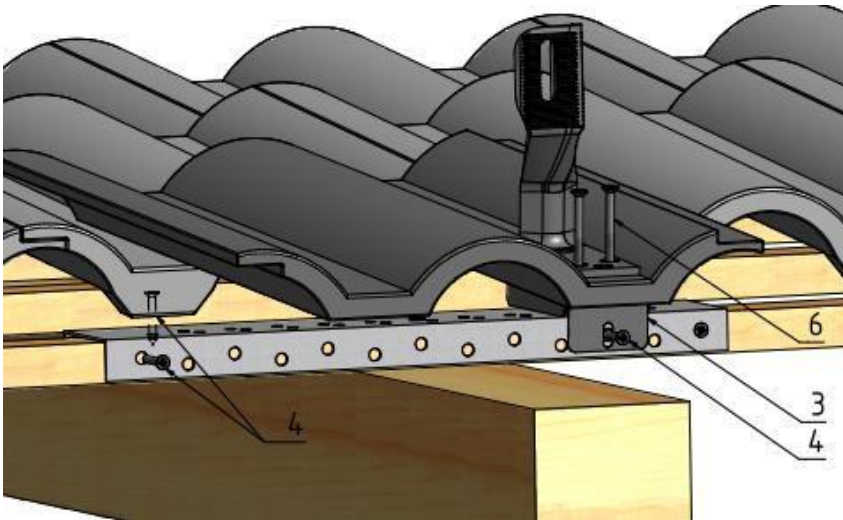


Figure 41: Connecting sheet metal roof tiles with batten rail

- Fit roof hooks using screws (6) and (4) and additionally secure the reinforcing runner to the batten using screw (4) (may alternatively be fastened from the top).

4.5.2 Fitting "Mammut Form S+" roof hooks on bitumen roofs

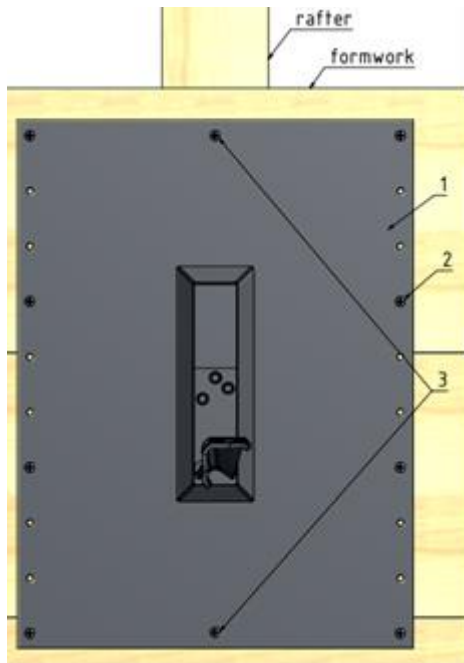


Figure 42: "Mammut Form S+ Bitumen"

Legend:

- (1) Roof hook
- (2) 4.8×32 mm drilling screw
- (3) 4.8×60 mm drilling screw

- Specify the roof hook position so that the roof hook (1) can be attached to the rafter using screws (3).
- Secure roof hooks to the roofing substructure using screws (2+3).
- In accordance with the valid specialist professional code and directives governing flat roofs set out by the association of German roofers (Deutsches Dachdecker Handwerk) the roof sealing must be certified by a specialist.
- The seal may be applied as follows:
 - Separately (polymer bitumen shingles)
 - Using self-adhesive components (roof sealing)
 - Thermally activated (gassed roof seal)

4.5.3 Fitting "Mammut Form S+" roof hooks on plain tile roofing

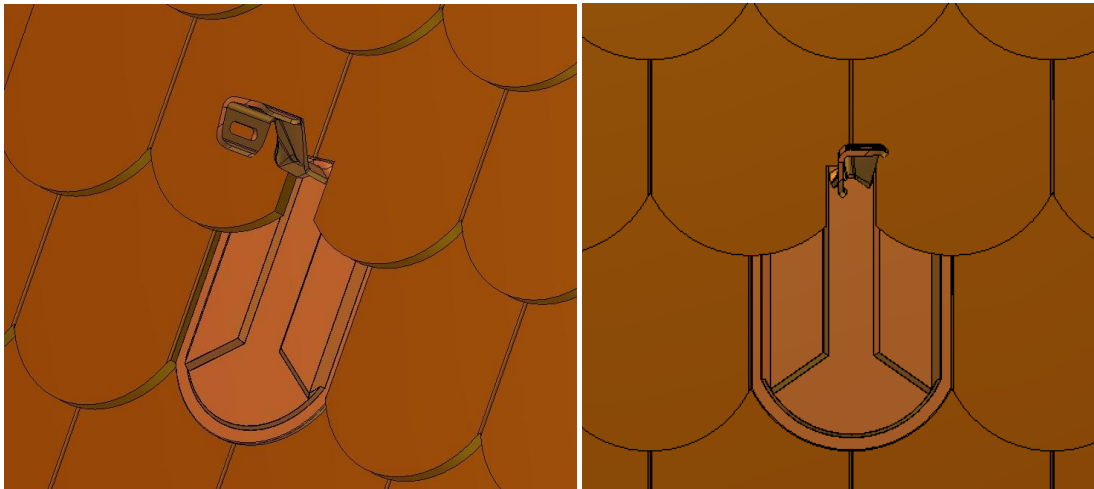


Figure 43: "Mammut Form S+" plain tile dual roofing

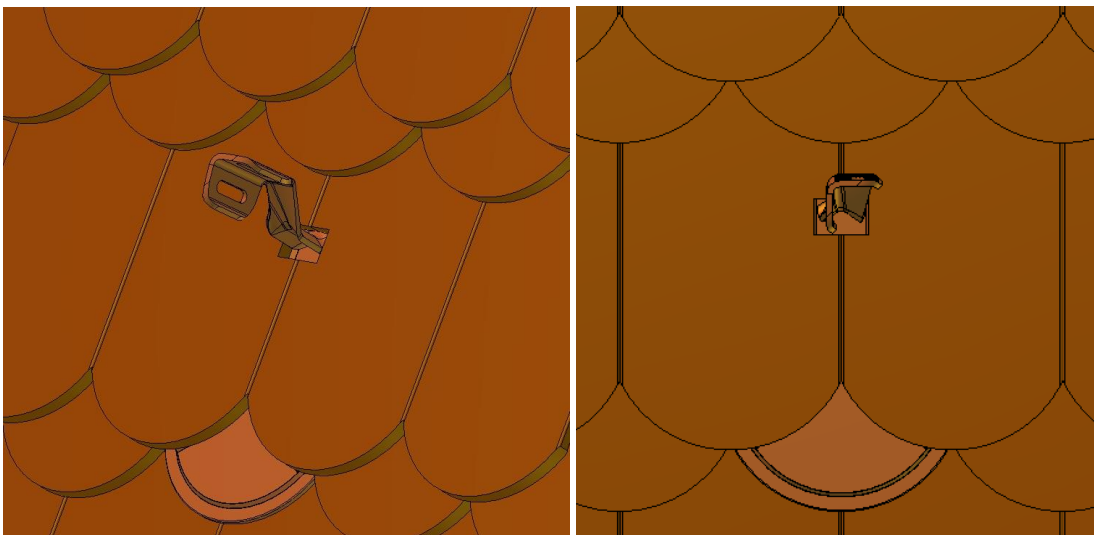
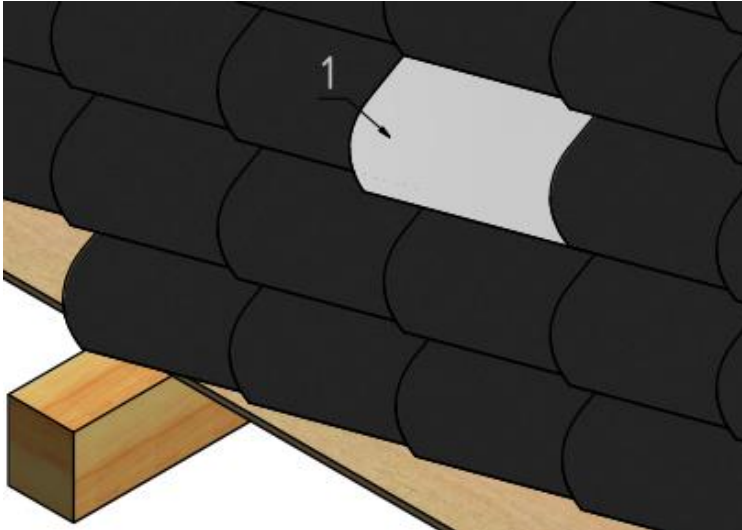


Figure 44: Mammut Form S+" plain tile crown roofing

4.5.4 Fitting „Mammut Form S+“ roof hook for slate and metal shingle roofs

Step 1:



Legend:

- (1) Metal plate
- (2) Mounting plate
- (3) Woodscrew 8x140 mm
- (4) cover cap
- (5) roof hook
- (6) Screw nut M6

Figure 45: Insert the metal plate (slate roof only)

- Fix the position of the roof hook in such a way, that this can be fastened with the screws in the rafter. Observe the edge distances according Figure 166
- Replace the slate plate with an individual manufactured metal plate (1). Not necessary for metal shingle roofs.

Step 2:

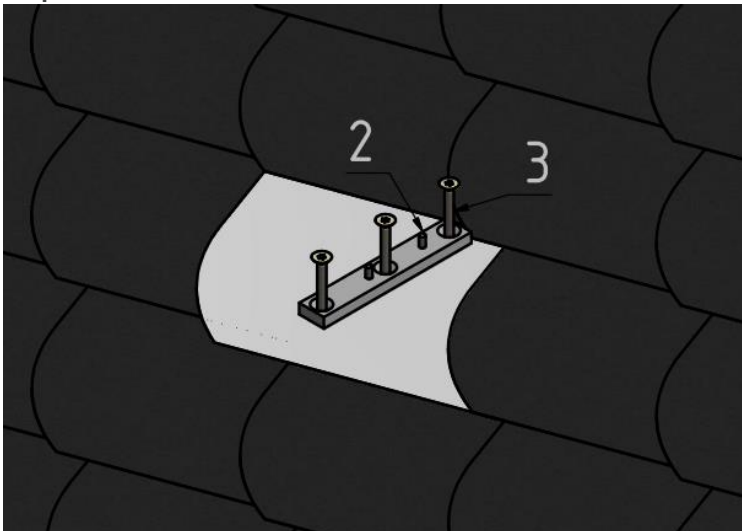


Figure 46: Fix the mounting plate

- Position the mounting plate (2) and fix it with the wood screws (3) in the rafter.



Important!

The mounting plate must lie completely on the metal plate or the metal shingle.

Step 3

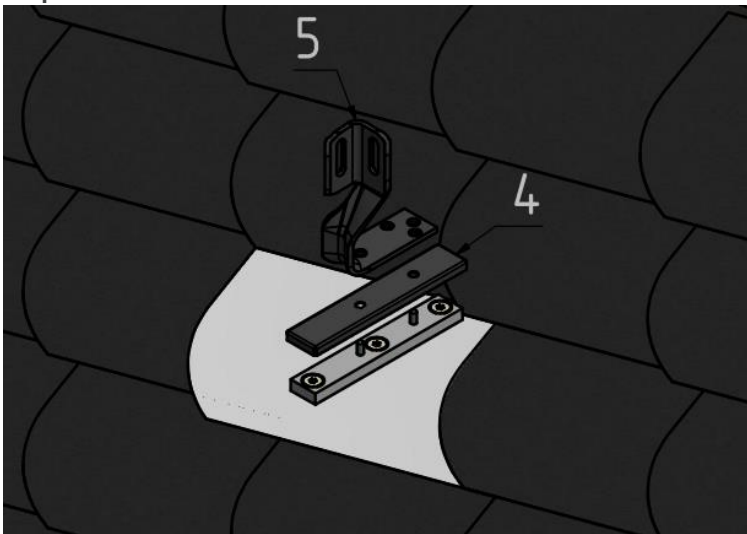


Figure 47: Cover cap and roof hook

Step 4

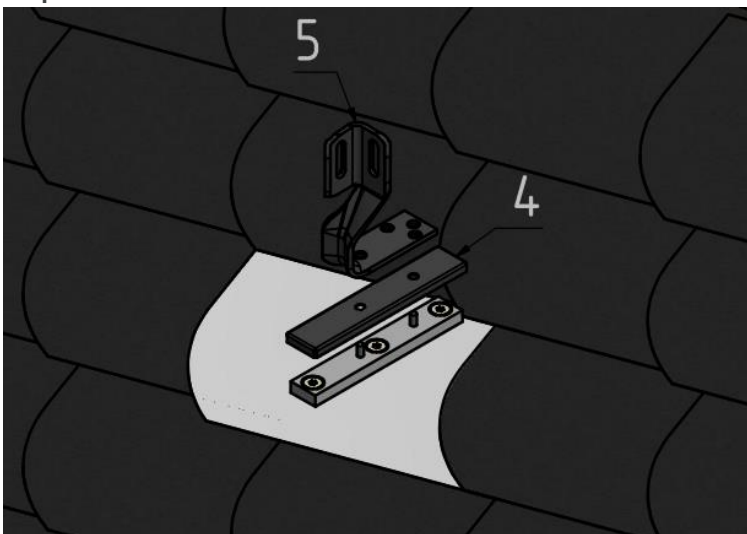


Figure 48: Roof hook fixing

Fix the cover cap (4) and the roof hook (5) at the mounting plate with the M6 nuts (6).
(torque 10 Nm)

4.6 Installation using M12x300, M12x250 and M10x200 hanger bolts on the timber substructure.



Hanger bolts are used on corrugated eternit and trapezoidal sheet metal roofs as well as bitumen roofs to attach the carrier rails. The load bearing roof construction to which the hanger bolt is secured consists of timber purlins or timber rafters.

Compensate for any difference in height of the purlins/rafters using the thread of the hanger bolts.

Comply with the valid, generally applicable building surveillance certificate Z-14.4-602 and the regulations contained therein for the use on trapezoidal roofs.

Figure 49: Hanger bolt

The roofing must not be damaged by pressure from the installed hanger bolts. If there is a risk of this, suitable measures must be taken to spread the load. Furthermore, the penetration point of the hanger bolts through the water conducting level should be sealed in accordance with roofing trade regulations. For this reason, we recommend having hanger bolts fitted by a roofing company. Please also observe the guidelines and regulations of the manufacturer of the respective roofing.

Proceed as follows during mounting:

- Do not drill into the water bearing depressions, but into the protruding parts.
- Use the pre-drilling diameters, screwing depths illustrated in Figure 50 and minimum dimension in Figure 166.

Hanger bolt	pre-drilling diameter [mm]	Screwing depth l_{ef} [mm]
Hanger bolt M12x300 A2	8,4	48...100
Hanger bolt M10x200 A2	7,0	40...67

Figure 50: pre-drilling diameters for plate and substructure; screwing depths for substructure

- Determine the rafter position (potentially mark using a piece of string). Drill the bores into the outer roofing (e.g. sheet metal, corrugated eternit) and rafters. Subsequently drill 15mm bores into the outer roofing.
- Tighten the lower nut on the machine thread to press the rubber seal against the outer roofing, thus sealing the hole.
- Carefully press down the seal. Risk of cracks and deformation!
- For stress reasons, the distance to the roofing must be kept as small as possible, see Figure 52: Fixing distance.

- Cut hanger bolts using an angle grinder if they protrude too far (comply with accident prevention regulations).
- For stress reasons, the universal connector must always be mounted in the direction of the roof ridge.

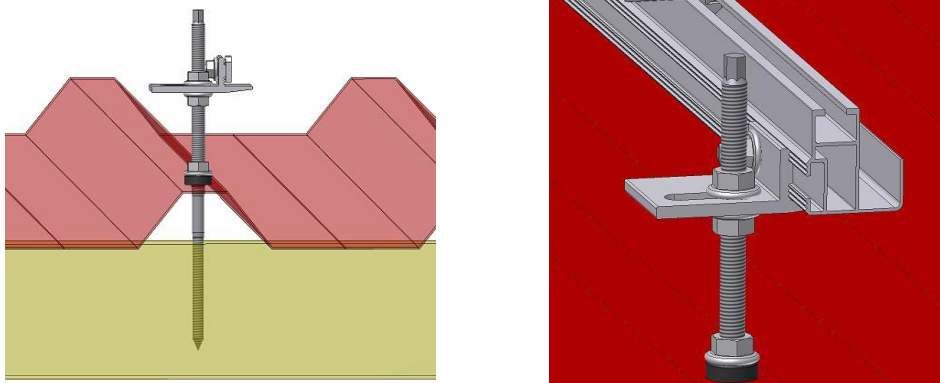


Figure 51: Correctly fitted hanger bolt with universal connector



Important!

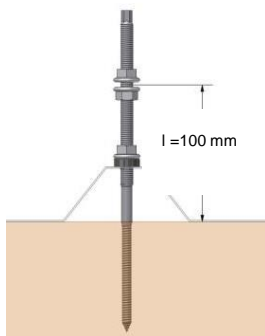


Figure 52: Fixing distance

The stress values for the M12x300 hanger bolt relate to a fixing distance $l = 100\text{mm}$ for a use of corrugated eternit panels. Exceeding the fixing distance has a detrimental effect on static values. The calculation in the PV Manager software is based on a fixing distance of $l = 100\text{ mm}$.



Important!

Always install universal connectors in each row of modules, as shown on the figure.

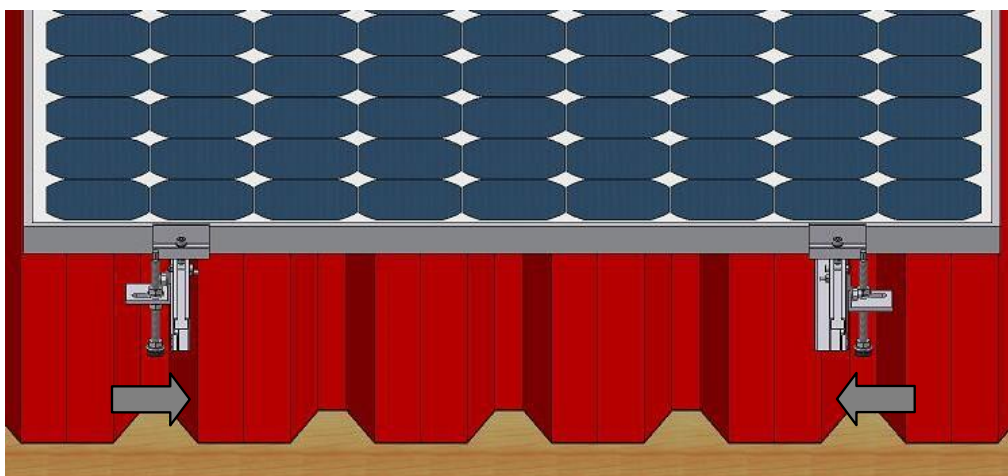


Figure 53: Mounted hanger bolt with "universal connector"

4.7 Assembly with solar fasteners on a steel substructure



Solar fasteners are intended for attachment to metal purlin or rafter structures with roofing made of trapezoidal profiles and sandwich profiles. In this process, the outer shell is made either of steel or aluminium.

Just as with hanger bolts, solar fasteners are inserted through the roofing and fastened to the substructure.

Comply with the valid, generally applicable building surveillance certificate Z-14.4-638 and the regulations contained therein for the use on trapezoidal sheet metal and sandwich roofs.

Figure 54: Solar fastener

Proceed as follows during mounting:

- Do not drill into the water bearing depressions, but into the protruding parts.
- Determine the rafter/purlin position (potentially mark using a piece of string).
- Drill 11 mm bores into the outer roofing (sheet metal).
- Depending on the thickness of the steel, drill into the metal substructure accordingly to fasten the solar fasteners. For this purpose, take into account the data illustrated in Figure 55 below.

	Thickness of the steel substructure [mm]			
	1.5 < 5.0	5.0 < 8.0	8.0 < 10	> 10
Pre-drilling diameter [mm]	6.8	7	7.2	7.4

Figure 55: Steel substructure pre-drilling diameter

- Screw the solar fastener into the steel substructure to safeguard it demonstrates secure static properties.
- Tighten the lower nut on the machine thread to press the rubber seal against the outer roofing, thus sealing the hole.
- Carefully press down the seal. Risk of cracks and deformation!
- For stress reasons, the universal connector must always be mounted in the direction of the roof ridge.
- Adapt the required length of the solar fastener to the height of the roof structure. Use IBC SOLAR AG's very own "PV Manager" planning software to ensure you select the right solar fastener.



Please note:

Comply with the following requirements regarding the roof profile type:

- The nominal sheet metal profile panel thickness around the fasteners is ≥ 0.4 mm for steel and ≥ 0.5 mm for aluminium.
- The nominal width of the outer layer of the sandwich element around the fasteners is ≥ 0.4 mm.
- The nominal width of the steel substructure (rafters/purlins) around the fasteners is ≥ 1.5 mm.
- The available rib height h for sandwich roofs is $35 \text{ mm} \leq h \leq 45 \text{ mm}$
- The available upper belt width b for sandwich roofs is $20 \text{ mm} \leq b \leq 40 \text{ mm}$
- When putting a load on solar fasteners in a transverse direction to the profile panels, the profile panels must be fastened to the corrugated elements on the substructure that are in the vicinity and at the same height.
- For additional framework conditions, see the valid version of the Z-14.4-638 certificate.

4.8 Mounting plate duo

The mounting plate duo is used for fixing with two hanger bolts or two solar fasteners. The two screws are connected through the mounting plate duo. The rooftop connector profile is then fixed on the mounting plate duo.

There are two different variants for connecting the profiles. For fixing a TF60 profile, only a RH-profile connecting element is required in accordance with Figure 57. For fixing the profiles TF50+ and TF50m, on the other hand, a universal connector and additional screws for fixing the universal connector are required in accordance with Figure 56.

The mounting plate duo can be used for trapezoidal sheet or corrugated eternit roof coverings. The maximum high-beading space must be 330 mm.

Component length mounting plate duo: 370 mm

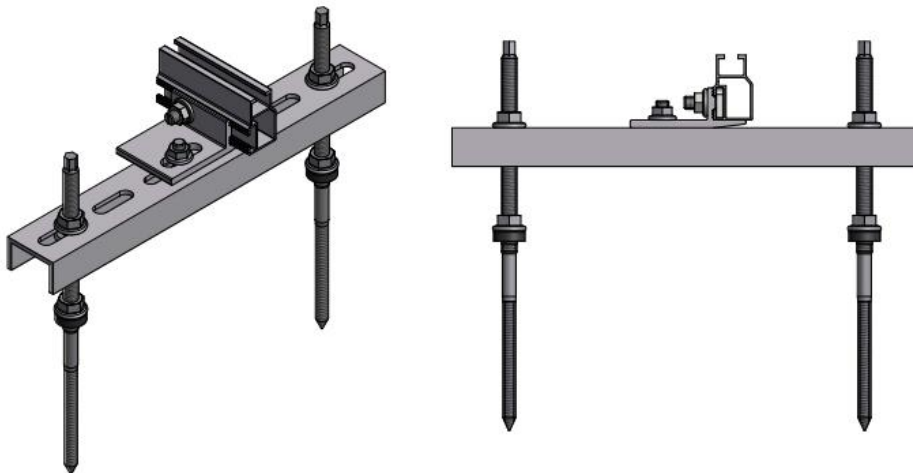


Figure 56: Mounting plate Duo with universal connector

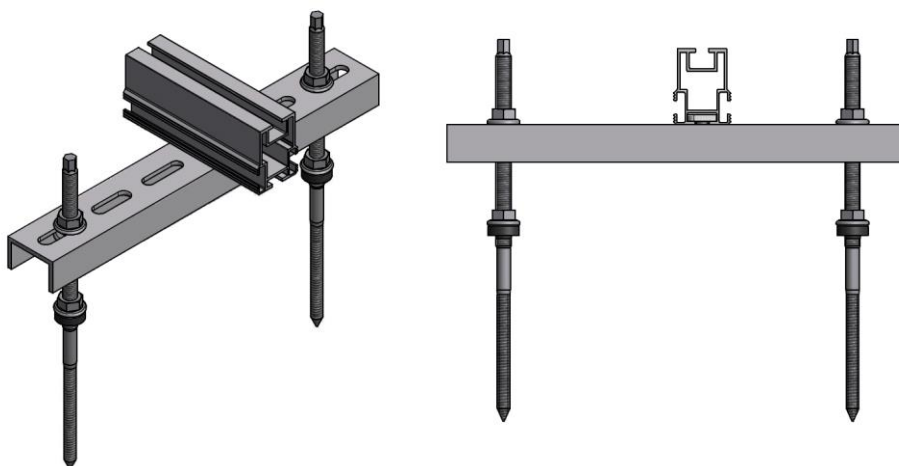


Figure 57: Mounting plate duo with connecting element RH-profile

4.9 Mounting with trapezoidal sheet metal clamps

4.9.1 Introduction

IBC SOLAR AG trapezoidal sheet metal mounting systems in combination with the IBC TopFix 200 mounting system is a fast, universal and structurally tested solution for attaching solar modules onto trapezoidal sheet metal roofs. It will be secured either by rivets or self drilling screws.



Please note:

- The minimum trapezoidal sheet thickness of steel or aluminium must be 0.5 mm.
- The enclosed special 4.8x15 blind rivets with flat, round head are certified for a sheet metal or aluminium thickness of between 0.5 mm and 1.5 mm.
- Observe the ETA-13/0255 for the blind rivets.
- The enclosed self drilling screws 5,5x25 are certified for a sheet metal or aluminium thickness of between 0.5 mm and 1.5 mm.
- Observe the ETA-10/0200 for the self drilling screws.
- Do not fall below the raised bead support width of 15 mm.
- The maximum width b of the raised bead must not exceed 40 mm.
- Because additional loads are created by the PV system in connection with the IBC mounting system and fixing points (fixed-points) and wind suction, the installer (contractor) has to check the statics of the load capacity of the roofing and the substructure, which normally requires the services of a structural engineer.
- Special-purpose assembly on narrow or wider raised beads, sandwich elements and elevations must be verified on-site as part of individual statics inspections and a certificate for trapezoidal sheet or sandwich profiles may have to be obtained from building surveillance authorities.



Important: Do not mount trapezoidal sheet clamps on the trapezoidal sheet metal panel blocks (two layers of sheet metal)!

4.9.2 Required tools/auxiliary agents*

- Riveter (by connection with rivets)
- Drill, Ø 5.0 mm (by connection with rivets)
- Socket wrench 6-kant SW8 (when mounted with self drilling screws)
- Cleaning agent
- Lint-free paper towels
- Cleaning fleece for badly contaminated roofs

* The listed tools and auxiliary agents are required exclusively for installation and processing of the trapezoidal sheet metal panels.

Information about tools for module and carrier rail mounting is provided in section 1 in these installation instructions.

4.9.3 Dimensioning

The mounting system is dimensioned in our very own PV Manager software, taking into account local conditions.



Important:

Do not exceed a maximum carrier profile length of 3 beams (approximately 15.60 m) for continuous carrier rails due to thermal expansion.

4.9.4 Mounting trapezoidal sheet metal panels

Step 1: Dimensioning using "PV Manager"

Step 2: Mark the fixing points of the clamp

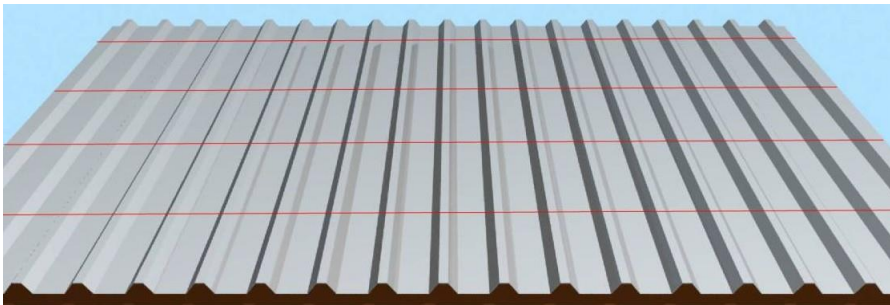


Figure 58: Marking fixing points

Step 3: Clean the roofing

Exclusively clean the roofing in areas where you intend to affix trapezoidal clamps at a later point. The surfaces must be dry and free from grease, oil or silicone as well as dirt particles to safeguard optimum integrity. In the event of heavy-duty contamination, we recommend to carefully roughen up the surface with suitable materials (e.g. fleece cleaning cloth) to subsequently clean it. We recommend using isopropyl alcohol or acetone in combination with lint-free paper towels for cleaning.



Important: Please observe the safety regulations when handling solvents and chemicals.

Step 4: Affix the TRAPEZOIDAL CLAMP



Note:

The heavy-duty adhesive tape can be used from an object and working temperature of 0° C; final adhesion occurs after approx. 72 h at an ambient temperature of 20° C. The higher the temperatures, the faster this process is complete.

We do not recommend to bond surfaces below these temperatures as the adhesive agent may become too hard and prevent adequate adhesion. After adhesion has taken place, low temperatures do not normally create any problems. Prevent the formation of condensation to safeguard appropriate adhesive properties, for instance in the event that the materials to be bonded together are at very different temperatures.

- TRAPEZOIDAL CLAMPS are aligned with the adjustable element towards the ridge and affixed to the surface so that the type TF27 carrier rail can be mounted without tension and it is in contact with the trapezoidal sheet clamp. Please fully remove the protective foil!



Figure 59: Removing the protective foil

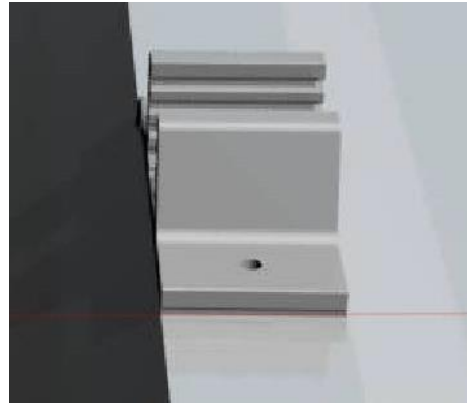


Figure 60: Affixing the trapezoidal clamp

Step 5: Distribute the clamps according to the instructions

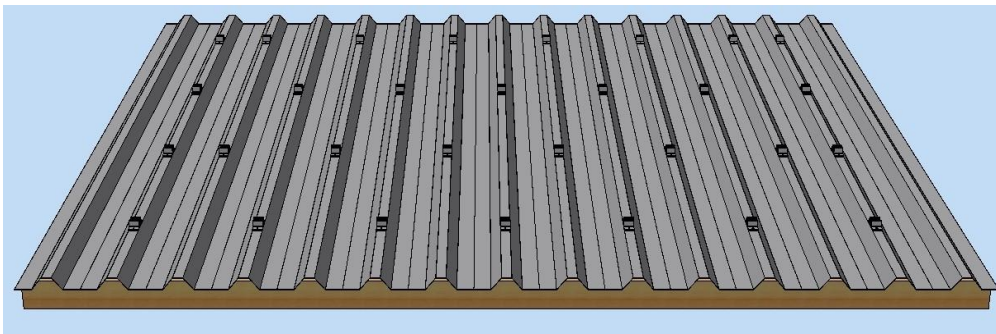


Figure 61: Distribute the clamps according to the instructions

Step 6: Insert and align the TF27-T carrier rail

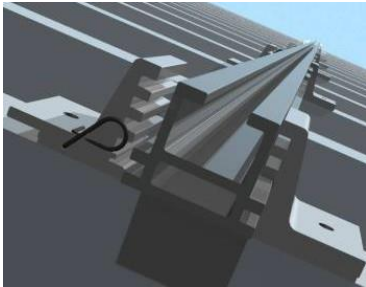


Figure 62: Insert the carrier rail

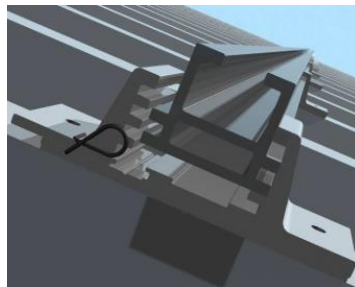


Figure 63: Align the carrier rail

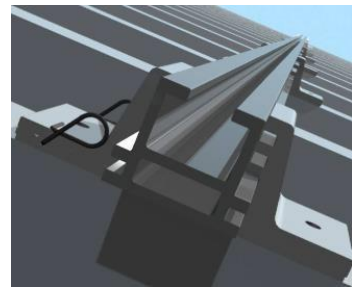


Figure 64: Close the clamp

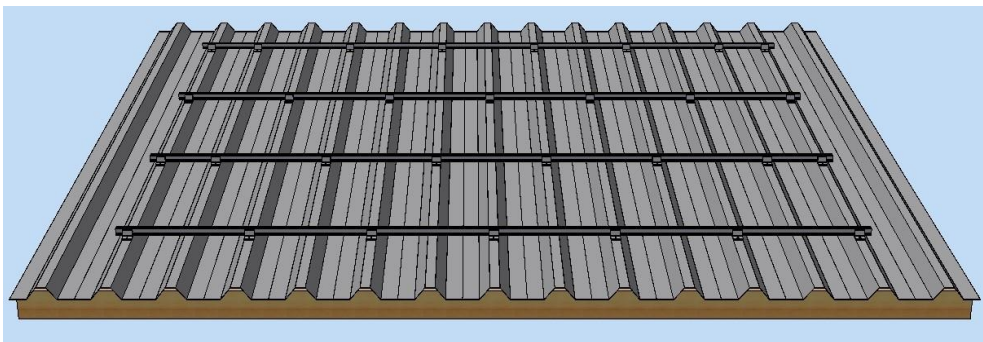


Figure 65: Mount carrier rail

Step 7A: Affix the TRAPEZOIDAL CLAMP to the outer roofing with blind rivets



Important:

A drill with a diameter of 5.0 mm is mandatory to maintain static properties!

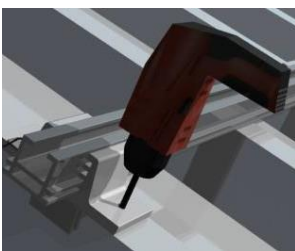


Figure 66: Drilling clamps

- When using the rivets drill two bores with a diameter of 5.0 mm per TRAPEZOIDAL CLAMP . In this process, make sure you drill carefully to maintain static properties.
- Now insert the 4.8x15mm blind rivets into the bores and rivet.
- The enclosed 4.8x15 mm blind rivets are approved for a sheet metal or aluminium thickness of 0.5 mm to 1.5 mm.

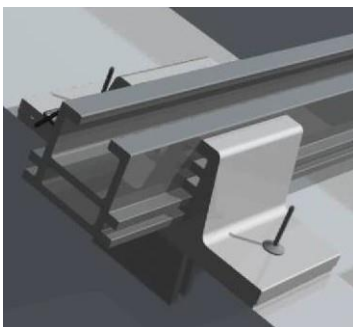


Figure 67: Inserting blind rivets

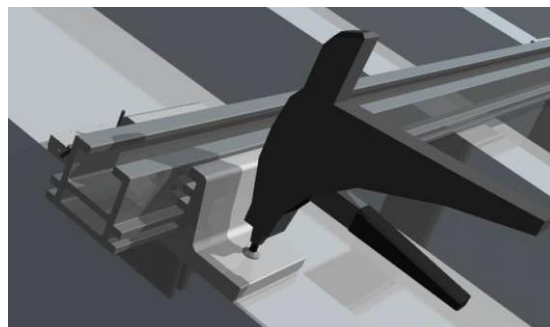


Figure 68: Riveting using a standard rivet head

Step 7B: Affix the TRAPEZOIDAL CLAMP to the outer roofing with self drilling screws

- When using the self drilling screws, two screws are placed per TRAPEZOIDAL CLAMP. In this process, make sure you screw carefully to maintain static properties.
- The enclosed self drilling screws 5,5x25 are approved for a sheet metal or aluminium thickness of 0.5 mm to 1.5 mm.



Important:

A drill with a diameter of 5.0 mm is mandatory to maintain static properties

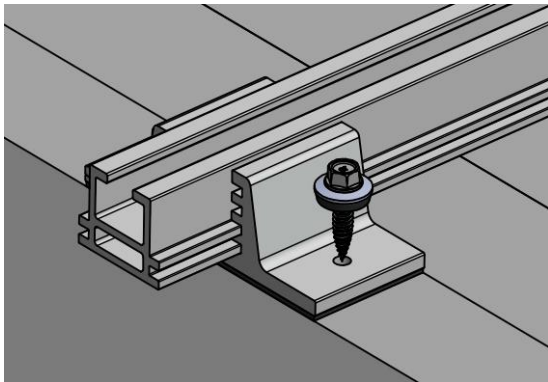


Figure 69: Apply the screw

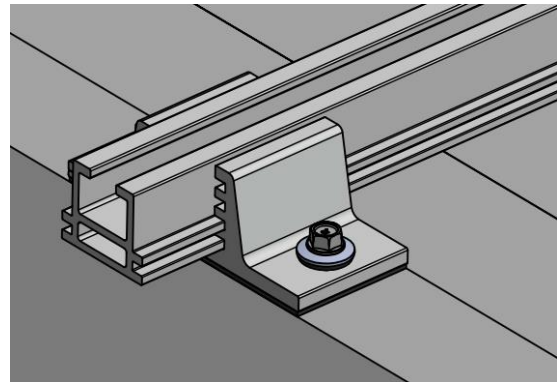


Figure 70: Trapezoidal clamp screwed

Step 8A: Insert and affix the transverse securing clamp with blind rivets

- The transverse securing clamps are affixed next to the trapezoidal clamp on the left and right with a clearance of approximately 20 mm.
- There must be a minimum of two transverse securing clamp per string (15.60 m).



Important:

Mount additional transverse securing clamps on roofs that are particularly exposed to wind.

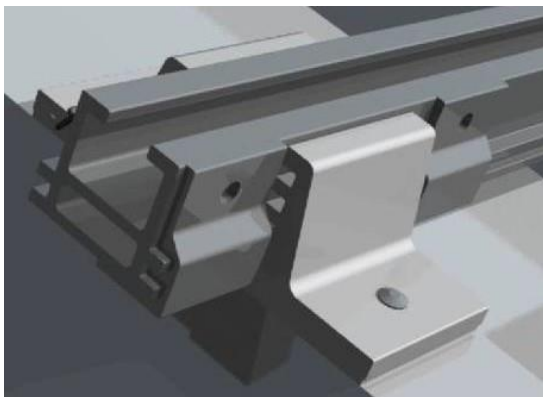


Figure 71: Insert transverse securing clamps

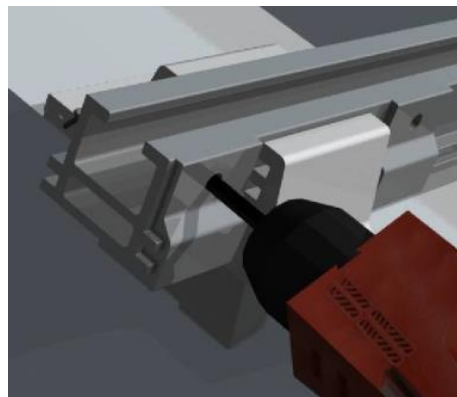


Figure 72: Drilling transverse securing clamps

- Now insert the 4.8x15mm blind rivets into the bores and rivet.

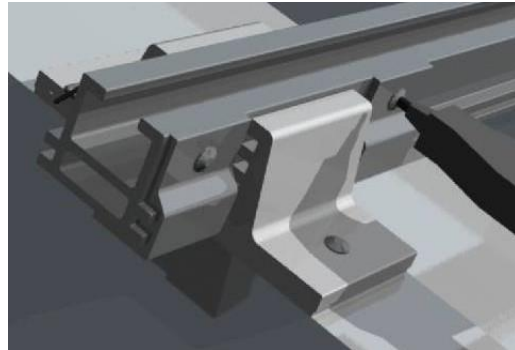
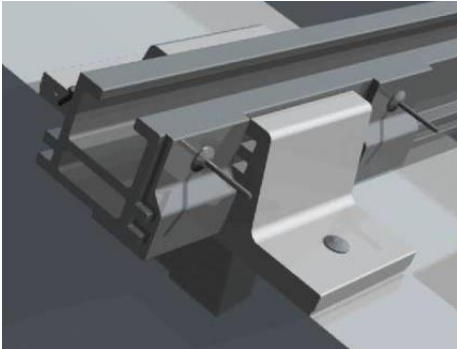


Figure 73: Rivet transverse securing clamps

Step 8B: Insert and affix the transverse securing clamp with self drilling screws

- The transverse securing clamps are affixed next to the trapezoidal clamp on the left and right with a clearance of approximately 20 mm.
- There must be a minimum of two transverse securing clamp per string (15.60 m).



Important:

Mount additional transverse securing clamps on roofs that are particularly exposed to wind.

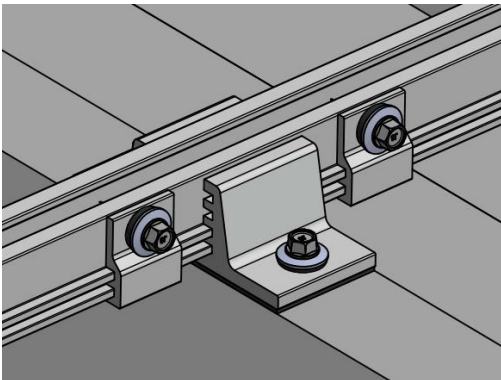


Figure 74: Screwed transverse securing clamps

Step 9: If required: Insert butt connector

- Butt connectors are inserted via the TF27 carrier rail and fixed.



Figure 75: Insert butt connectors



Figure 76: Joining together the carrier rails

- The butt connector is either attached using two 4.8x15 mm blind rivets (pre-drilling) or two 5.5x25 mm self drilling screws.

4.9.5 Trapezoidal sheet elevation

The trapezoidal sheet elevation is a combination of the trapezoidal sheet metal mounting listed in 4.9.4 and the AeroFix supports. The modules can only be installed landscape



Important:

The system is not wind tunnel tested and must be verified on site by a structural engineer.

Step 1: Fix the TRAPEZOIDAL CLAMP and support profile TF27 at the correct distance

The TRAPEZOIDAL CLAMP and support profiles are mounted as described in 4.9.4. The support profiles must be laid parallel at an axial distance of module length + 20 mm.

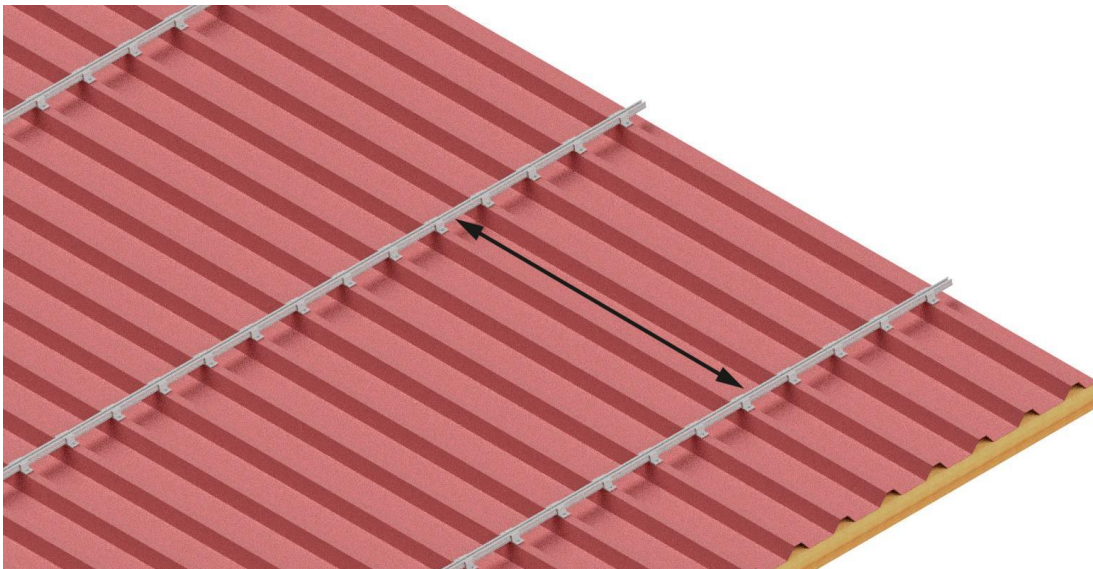


Figure 77: Gap = Module length + 20 mm

Step 2: Position of the Bottom Support

It is recommended to maintain the AeroFix standard grid spacing from the front edge Bottom Support to the front edge next Bottom Support. These are as follows

- AeroFix 15-S 1,8 m (variable 1,62 m – 1,98 m)
- AeroFix 10-S 1,6 m (variable 1,44 m – 1,76 m)
- AeroFix 10-EW 2,3 m (not variable)

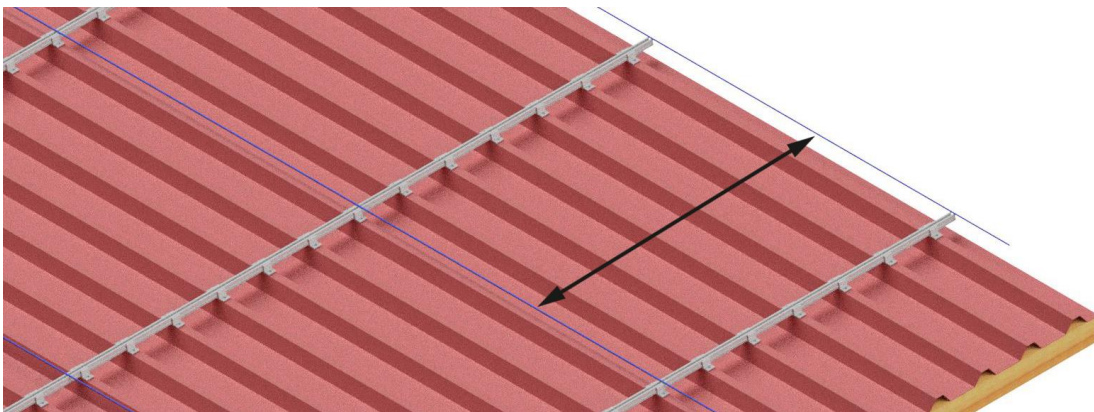


Figure 78: Mark the position of the Bottom Support in the grid spacing

Step 3: Fasten Bottom Support

For easier installation, the screw with the rhombus nut should be mounted on the support before.

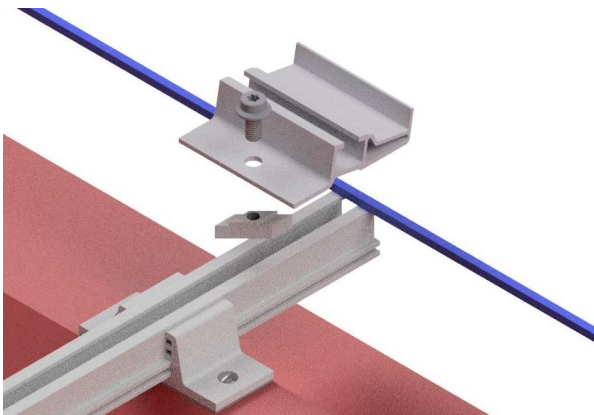


Figure 79: Bottom Support with screw and rhombus nut

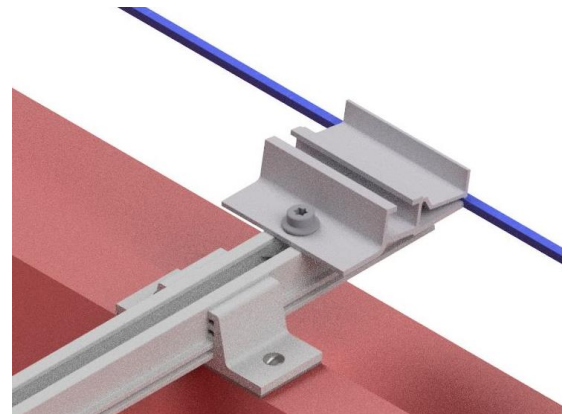


Figure 80: Mounted Bottom Support

Setp 4: Distance Bottom Support / Top Support

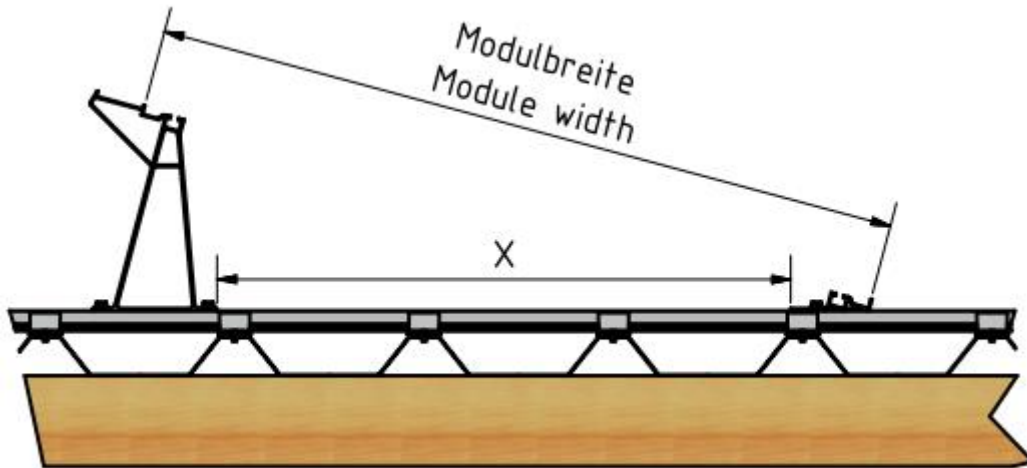


Figure 81: Distance AeroFix 15-S supports

Distance between supports AeroFix 15-S	
Module width	Distance x
950 mm	715 mm
960 mm	725 mm
970 mm	736 mm
980 mm	746 mm
990 mm	756 mm
1000 mm	767 mm

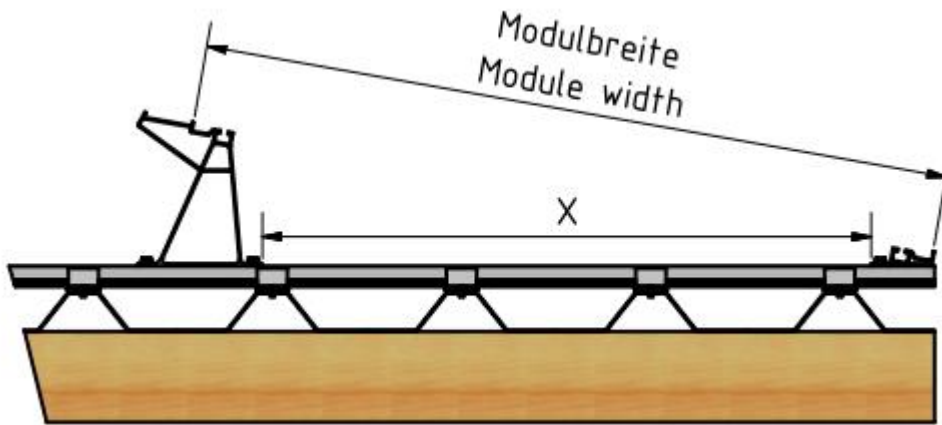


Figure 82: Distance AeroFix 10-S supports

Distance between supports AeroFix 10-S	
Module width	Distance x
950 mm	763 mm
960 mm	773 mm
970 mm	783 mm
980 mm	793 mm
990 mm	803 mm
1000 mm	813 mm

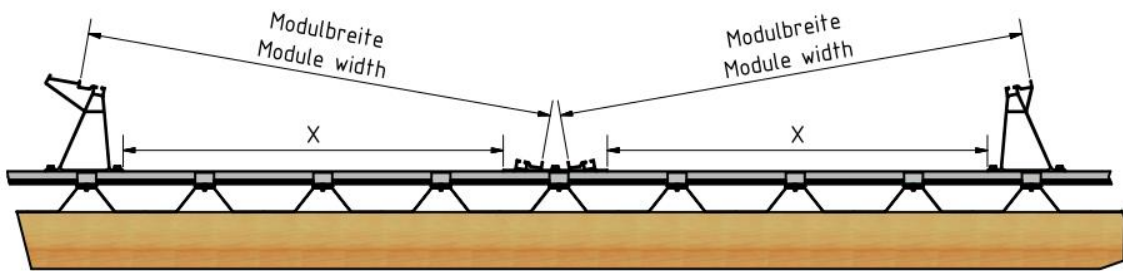


Figure 83: Distance AeroFix 10-EW supports

Distance between supports AeroFix 10-EW	
Module width	Distance x
950 mm	763 mm
960 mm	773 mm
970 mm	783 mm
980 mm	793 mm
990 mm	803 mm
1000 mm	813 mm

Step 5 Mounting Top Support

For easier installation, the screws with the rhombus nuts should be mounted on the support before.

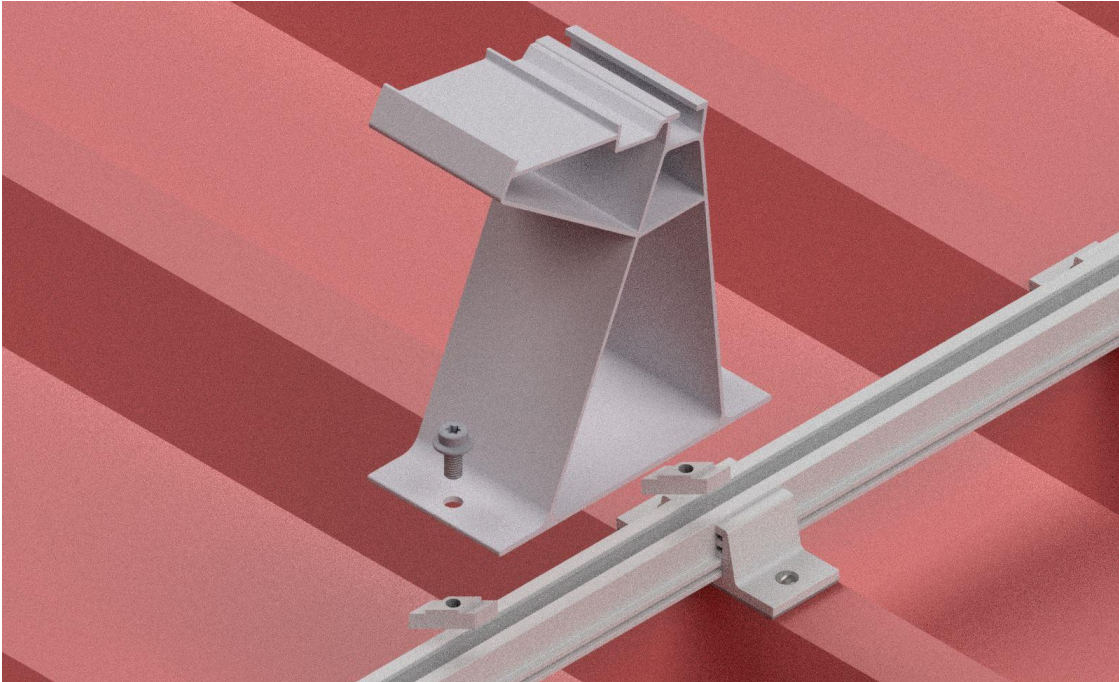


Figure 84: Fasten Top Support with two screws and rhombus nuts

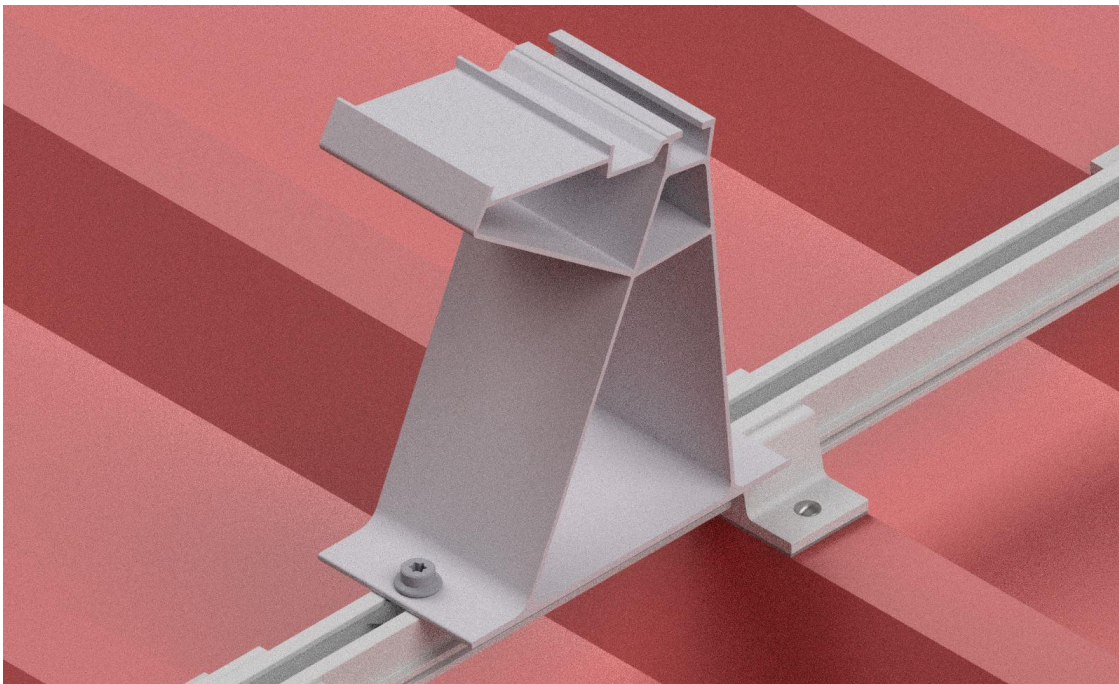


Figure 85: Mounted Top Support

Step 6 Module assembly

The procedure for the module assembly is identical for all supports.

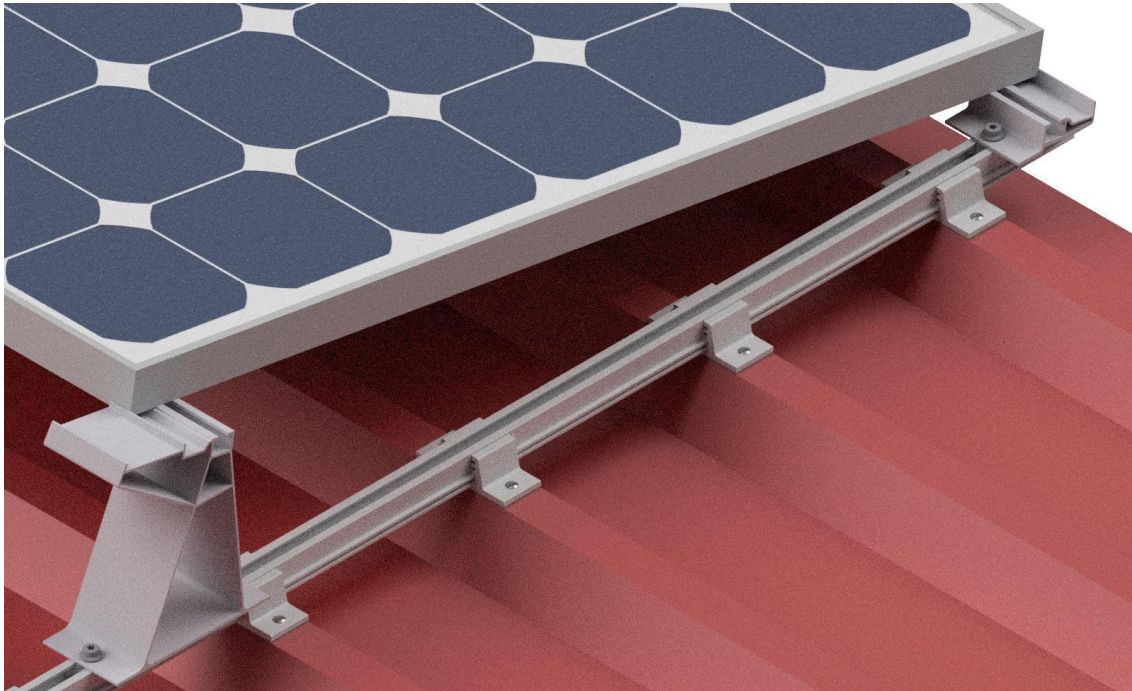


Figure 86: Insert the module in the Bottom Support and Top Support



Figure 87: The module must rest against the Top Support (with wind plate-end)

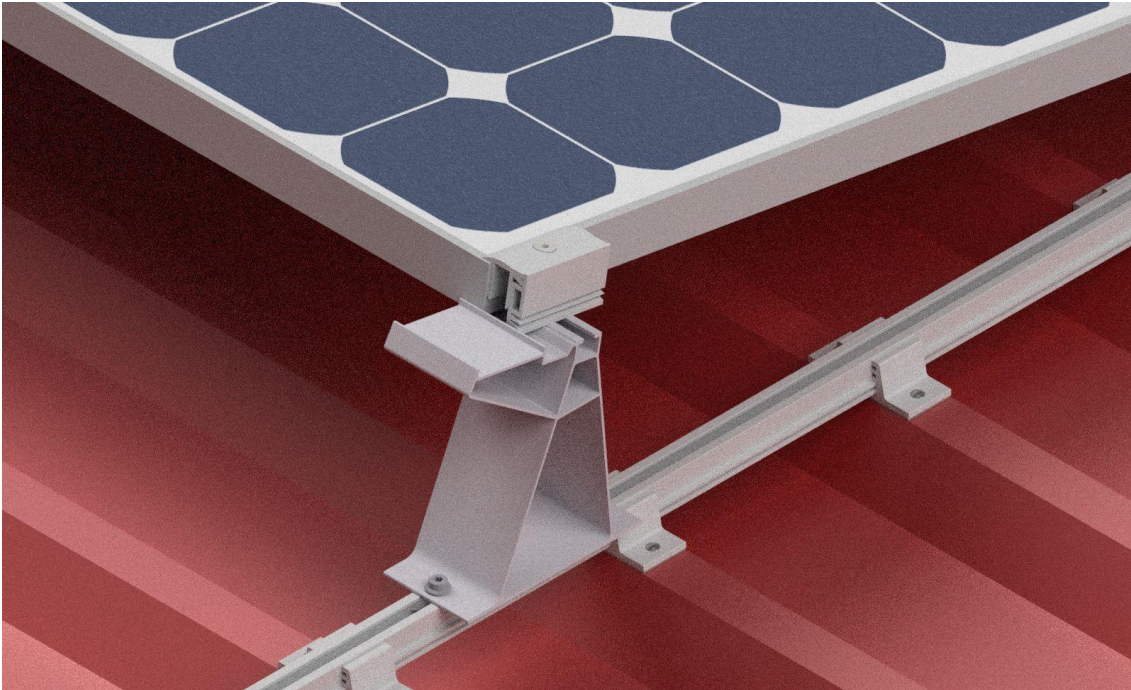


Figure 88: Module at the stop of the Top Support and clamped

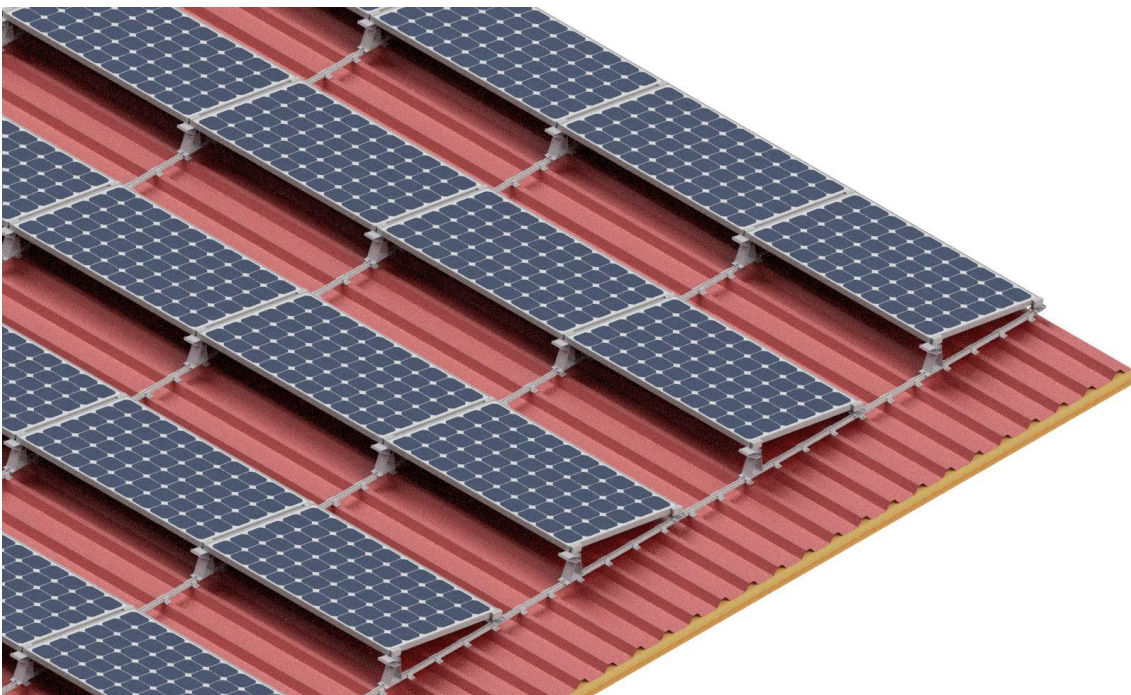


Figure 89: Mounted modules

Step 7 Wind plate assembly

The system is not wind tunnel tested. The wind plate is therefore not mandatory. However, it is still recommended to use it. The wind loads can thus be reduced.

Beginning with the rear side of the left module row, mount the wind plate on the supports. Screw the left side of the wind plate to the TF27 rail with screw M8x16. Slide the wind deflector for the next module sideways on the previously mounted plate and mount onto the next support. Ensure that the lateral tabs clasp the wind plate. Screw both plates onto the TF27 rail. The gap between screw and end of the TF27 rail should be at least 3 cm. Repeat process with the other wind plates in the row.

The first and last wind plates in the module row or single wind plates have to be attached with a sheet-metal screw to the support (Figure 93: Fixed wind plate on the Top Support at the beginning / ending of the row Figure 93).

For AeroFix 10-EW, wind plates and AeroFix 10S "Top Support" are only required on the modules if

- the first/last row begins/ends with an "Top Support"
- individual modules are omitted with a module field

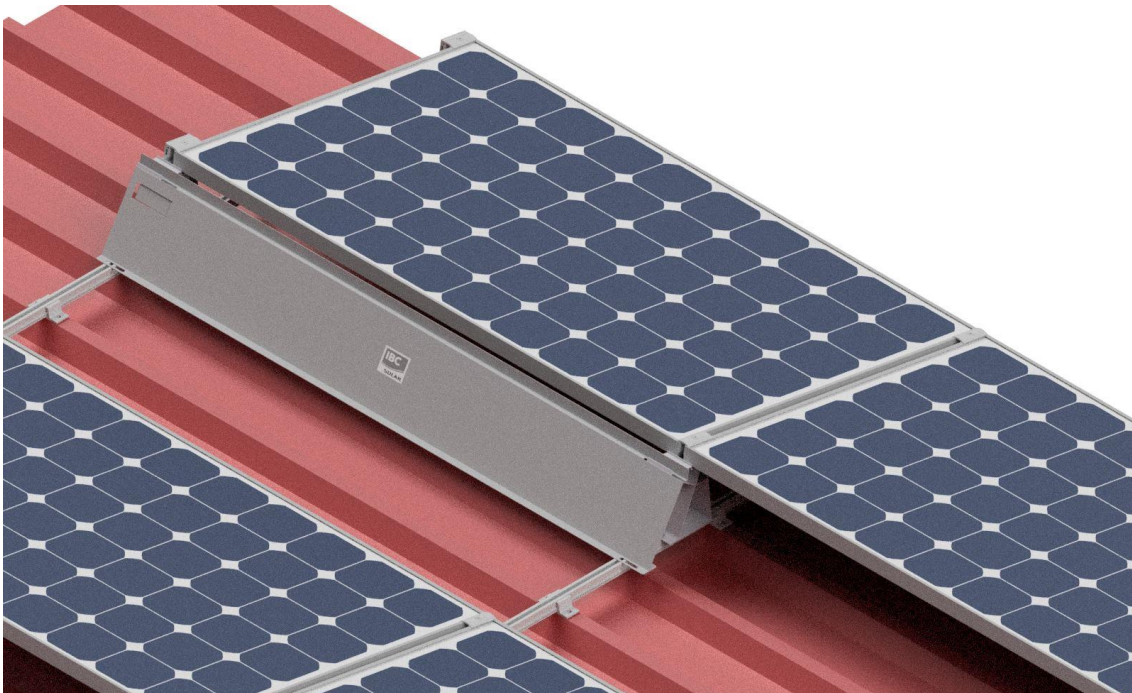


Figure 90: Wind plate assembly starting from the left

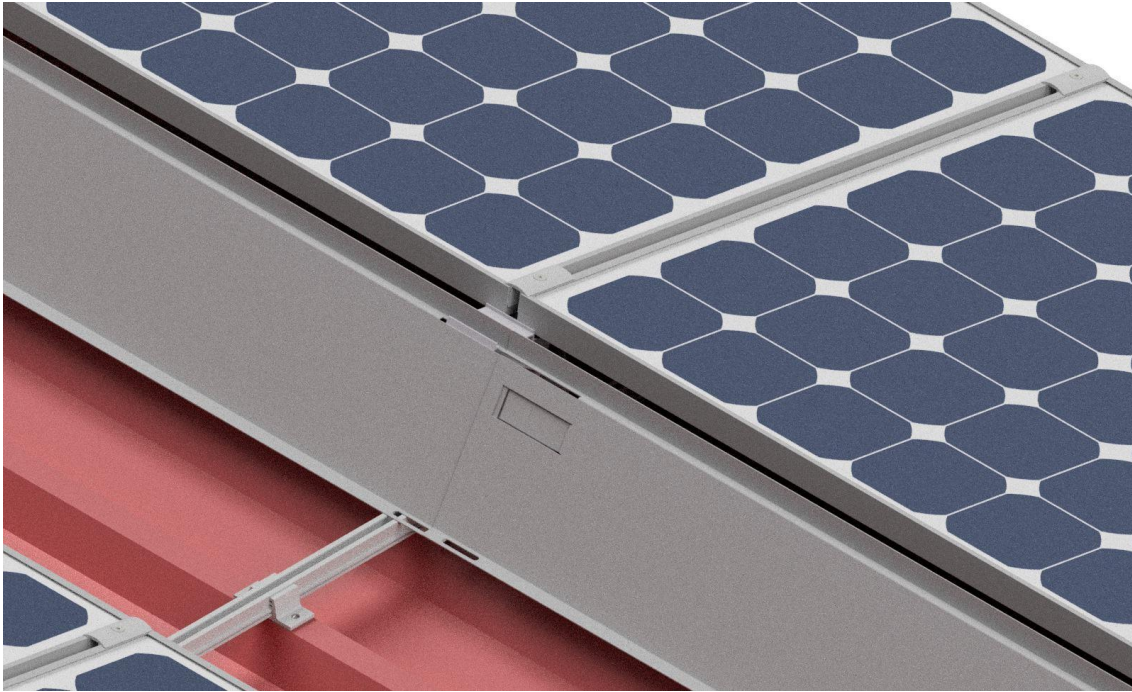


Figure 91: Insert wind plate

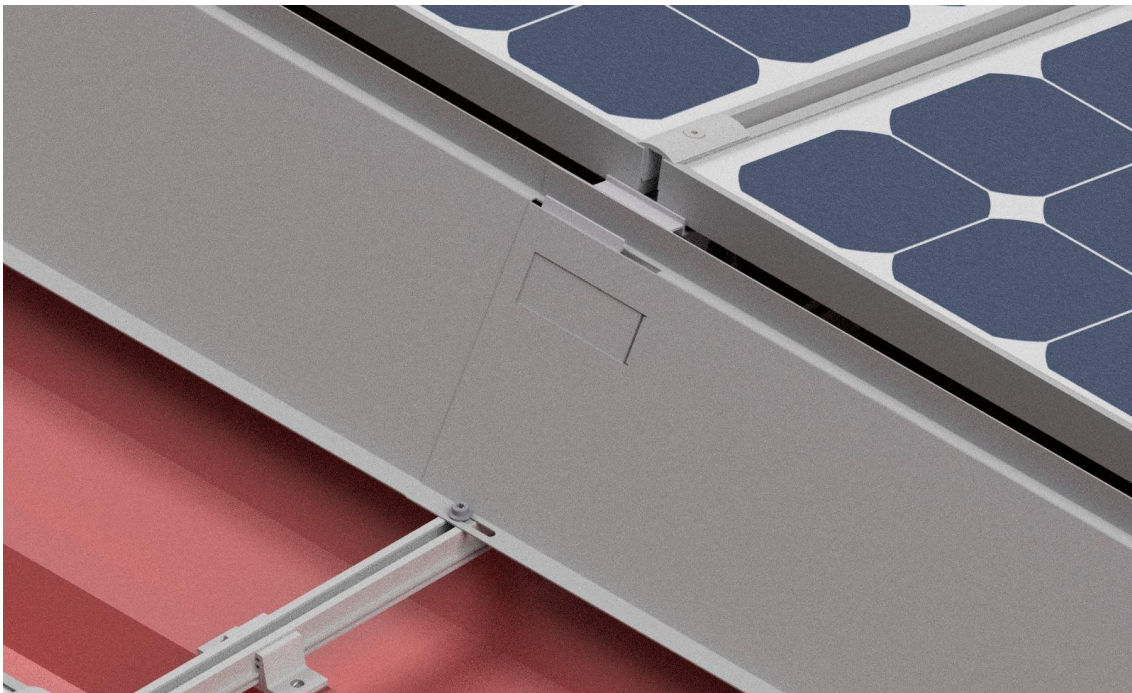


Figure 92: Fixed wind plates within the row

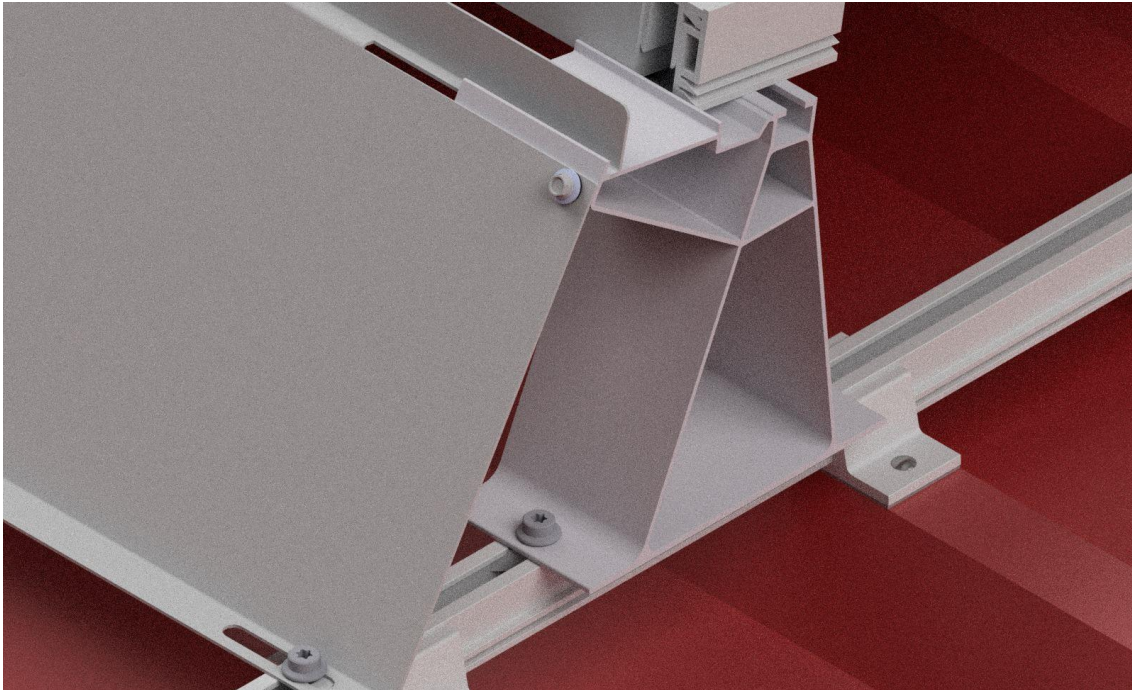


Figure 93: Fixed wind plate on the Top Support at the beginning / ending of the row

4.9.6 Eco trapezoidal system

The trapezoidal system Eco is a pre-assembled, short-rail system to which trapezoidal profiles are riveted or screwed together.

- Trapezoidal System Eco 340 mm: maximum raised bead distance 250 mm
- Trapezoidal System Eco 420 mm: maximum raised bead distance 333 mm



Important:

Thermal expansion dictates a thermal separation after 15 modules in one row.

Step 1: Dimensioning using "PV Manager"

Step 2: Mark the fixing points of the clamp

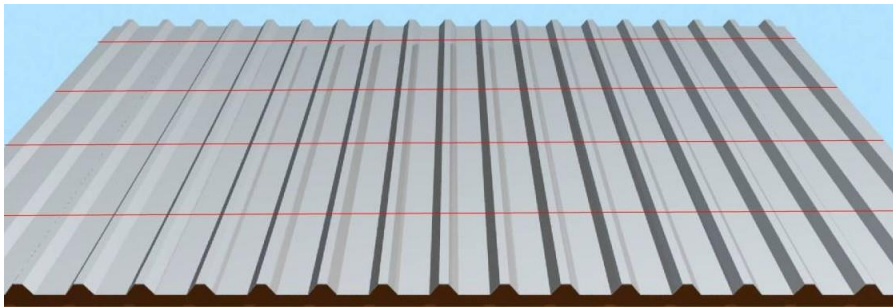


Figure 94: Marking fixing points

Step 3: Clean the roofing

Exclusively clean the roofing in areas where you intend to affix trapezoidal clamps at a later point. The surfaces must be dry and free from grease, oil or silicone as well as dirt particles to safeguard optimum integrity. In the event of heavy-duty contamination, we recommend to carefully roughen up the surface with suitable materials (e.g. fleece cleaning cloth) to subsequently clean it. We recommend using isopropyl alcohol or acetone in combination with lint-free paper towels for cleaning.



Important: Please observe the safety regulations when handling solvents and chemicals.

Step 4: Affixing the "Eco trapezoidal system"



Figure 95: Removing the protective foil

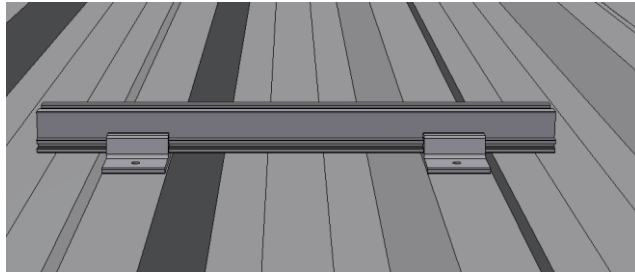


Figure 96: Affixing the "Eco trapezoidal system"

Step 5: Distributing the "Eco trapezoidal system" as specified

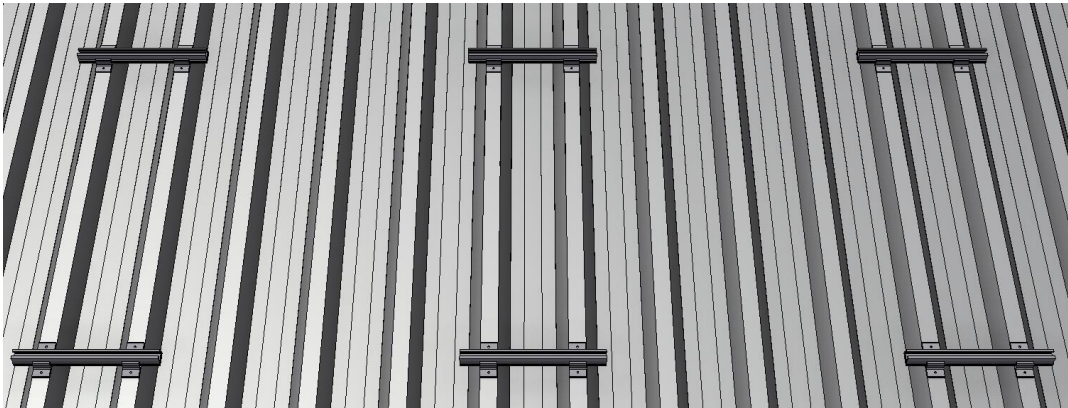


Figure 97: "Eco trapezoidal system" distributed as specified

Step 6A: Affix "Eco trapezoidal system" to the outer roofing with blind rivets



Important:

A drill with a diameter of 5.0 mm is mandatory to maintain static properties!



Figure 98: Drilling clamps

- When using the rivets drill two bores with a diameter of 5.0 mm per "clamp base". In this process, make sure you drill carefully to maintain static properties.
- Now insert the 4.8x15mm sheet blind rivets into the bores and rivet.
- The enclosed 4.8x15 mm sheet blind rivets are approved for a sheet metal or aluminium thickness of between 0.5 mm and 1.5 mm.

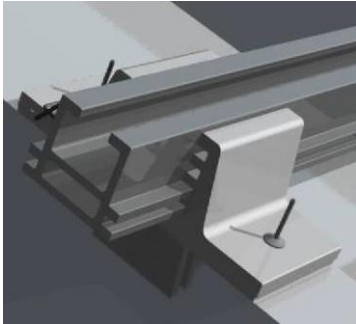


Figure 99: Inserting blind rivets

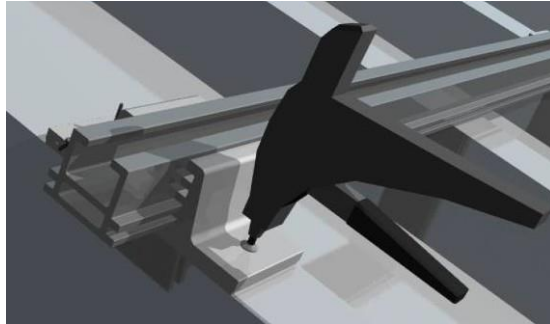


Figure 100: Riveting using a standard rivet head

Step 6A: Affix "Eco trapezoidal system" to the outer roofing with blind rivets

- When using the self drilling screws, two screws are placed per "clamp base". In this process, make sure you screw carefully to maintain static properties.
- The enclosed self drilling screws 5,5x25 are approved for a sheet metal or aluminium thickness of 0.5 mm to 1.5 mm.

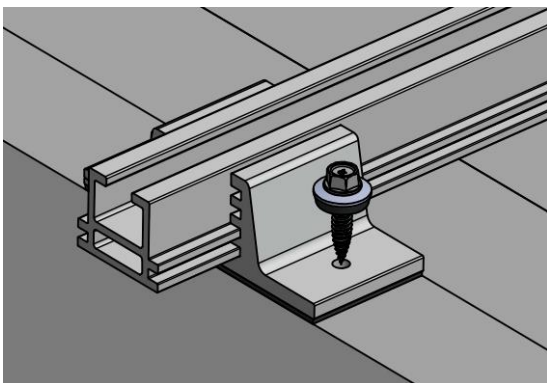


Figure 101: Apply the screw

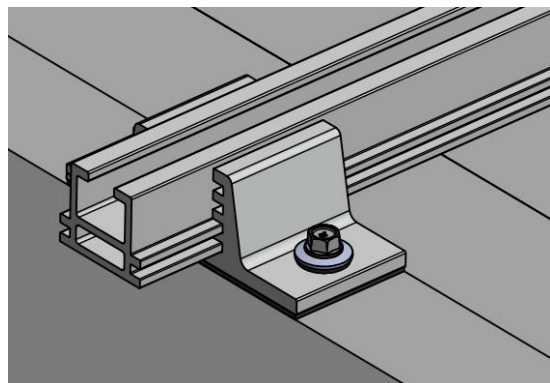


Figure 102: Eco trapezoidal screwed

Step 7: Alignment of PV modules

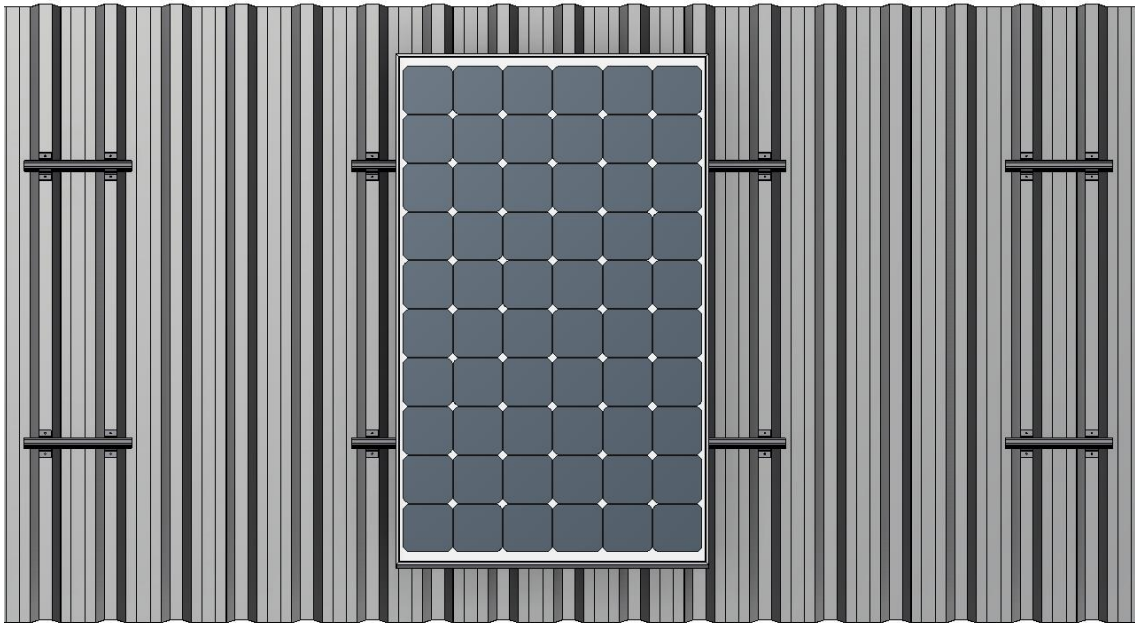


Figure 103: Aligning PV modules

4.10 Installation of sheet seam clamps

Special fastening elements are used to fasten PV modules on standing seam roofs, which are then attached to the carrier rails or module clamps.

The roofing must not be damaged by the load on the installed clamps. For this reason, we recommend having sheet seam clamps fitted by a roofing company. The tightening torque of the sheet seam clamp must be limited in such a way that the sheet metal is not deformed and the thermal expansion of the sheets is not hindered.



The clamps are mounted vertically according to the number of modules or carrier rails. As a rule, fit one standing seam to each clamp. On each side the carrier rail must protrude by a maximum of 0.3 m. Observe the thermal separations of the profiles after 3.1m or the specifications of the respective sheet seam manufactures.

Figure 104: Universal Metal Seam Clamp G2

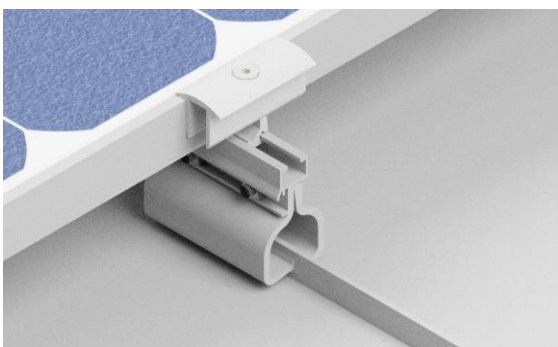


Figure 105: Direct assembly

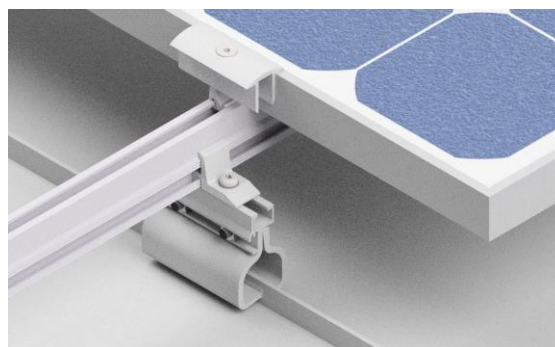


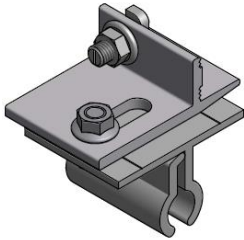
Figure 106: with support rail and 2-layer connector



Important!

Clarify on site whether the roof and the substructure are able to withstand the additional forces caused by installing the PV system. If you intend to assemble PV plants on standing seam roofs, the roof must not only carry the additional loads, it must also withstand the additional wind dynamics. A structural engineer must check the number of fixing points (sheet seam clamps) according to the on-site conditions. The position of the metal seam clamp should not be on a retaining clip of the metal seam. In case of doubt, a roof expert should be consulted. Keep the alternator size to a minimum to minimise occurring voltage values. A connection on titan's zinc roofs or copper roofs is not recommended. In advance the clamp should be checked for correct fit and material compatibility.

4.11 Installation of Kalzip® clamps



Use "Kalzip® clamps" to fasten the system on so-called Kalzip® roofs. The clamps are distributed vertically according to the number of cross girders. As a rule, fit one standing seam to each clamp. On each side the carrier rail must protrude by a maximum of 0.3 m.

Figure 107: Kalzip® clamp with universal connector



Important!

Clarify on site whether the roof and the substructure are able to withstand the additional forces caused by installing the PV system. If you intend to assemble PV plants on standing seam roofs, the roof must not only carry the additional loads, it must also withstand the additional wind dynamics. A structural engineer must check the number of fixing points (sheet seam clamps) according to the on-site conditions. Keep the alternator size to a minimum to minimise occurring voltage values. A connection on titan's zinc roofs or copper roofs is not recommended. In advance the clamp should be checked for correct fit and material compatibility.

Please also take into account the manufacturer's specifications for the corresponding roofing, as well as the specifications of the corresponding general building approval Z-14.4-560!

05. Fitting carrier rails

- Insert the pre-assembled securing screw (M10 connection piece for roof hook profile) through the roof hook slot. Rotate by 90° and insert into the mounting groove of the e.g. TF50+ carrier rail. Connect TF50+ carrier rail to the roof hooks at the required height and tighten the screw.



Important: Please ensure all teeth of the type e.g. TF50+ carrier rail have engaged in the recess!

- Start with the top or the bottom carrier rail. Align the screws with the fixing points (e.g. roof hooks) and secure them. See Figure 108.
- Align the other carrier rails with each other by means of a cord.
- If required, extend the carrier profiles using butt connectors. Butt connectors enable ideal alignment of the carrier rails.
- Do not exceed a maximum carrier rail length of 3 rods (approximately 15,60 m) for continuous carrier rails due to thermal expansion.
- Prevent any water from collecting in the carrier rails to prevent frost damage.

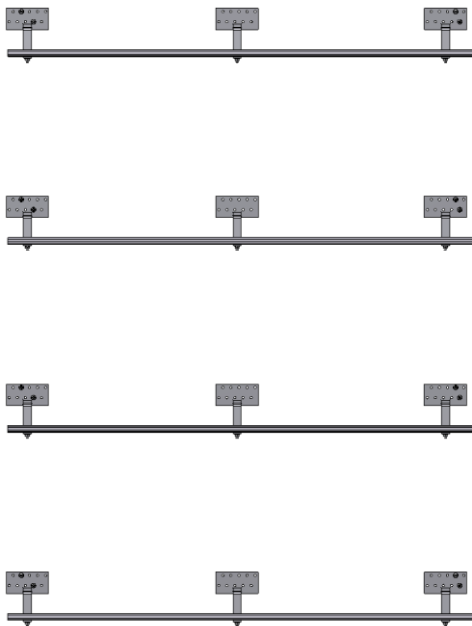


Figure 108: Carrier rail, fitted

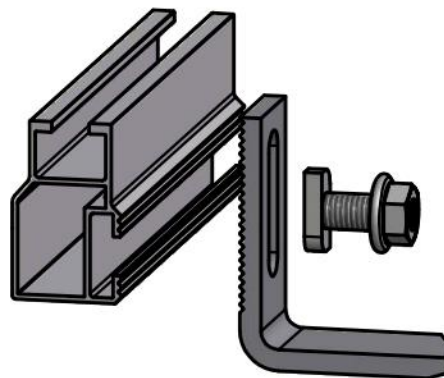


Figure 109: Mounting carrier rails

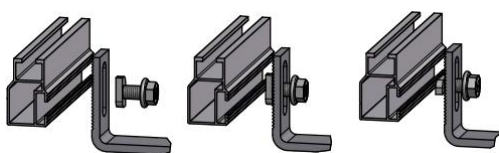


Figure 110: Fitting carrier rails



Important! Do not use fitted carrier rails as step ladders!

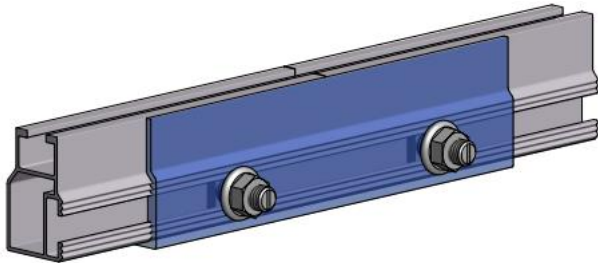


Figure 111: Butt connectors for type TF50 carrier rails



Important!

Ensure that all T-head screws and hammer nuts have engaged with the rail so they are completely inserted.

The support rail pieces must be fastened to at least two support points before a butt connector may be installed. Not more than one butt connector may be installed within two support points.

Note:

- Interlocking has been provided on roof hooks and type e.g. TF50+ carrier rails to compensate for differences in height on uneven roofs.
- Any carrier rails installed above each other must be in parallel. For this purpose, align the bottom carrier rail horizontally first.
- The ends of the rows must be aligned at an exact right angle (90°) to the bottom rail, as otherwise it will not be possible to align the joints between the modules.
- Once the carrier rails have been aligned, re-tighten IBC SOLAR AG screws to the corresponding tightening torque and re-check.

06. Fitting PV modules

The middle and outer clamp are delivered pre-assembled.

The middle clamp G3 covers a clamping area of 30-50 mm.

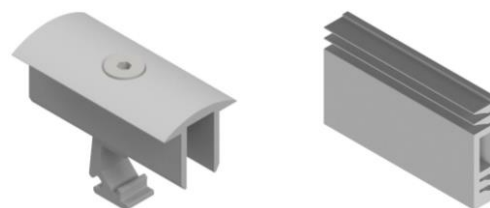
However the outer clamp G3 must be ordered for each module height.

The middle clamp G4 covers a clamping area of 33-46 mm.

The EC adapter is installed with the middle clamp G4 or G3 and replaces the traditional outer clamp.



G3 Middle and outside clamp



G4 middle clamp and EC adapter



Important information:

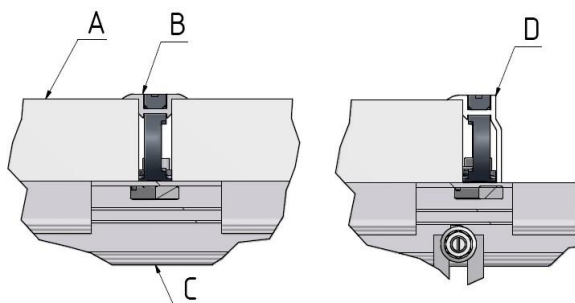
Depending on the height of the module frame, a different version of the outer clamp G3 will be required.

The EC adapter for G4 middle clamp covers only the frame sizes 33, 35, 38, 40, 45 and 46mm.

The tightening torque of the clamps must 15 Nm!

Do not use a ratchet or a wrench with high leverage as the maximum tightening torque could easily be exceeded.

Please only use a Torx screwdriver with T-handle or cordless screwdrivers with the appropriate torque settings.



A	Solar module
B	G3 Middle clamp
C	TF50+ carrier rail
D	G3 Outside clamp

Figure 112: Assembled clamps (sectional view)

- The middle and outside clamps can be inserted into the carrier rail directly from the top, into the position where they are required.

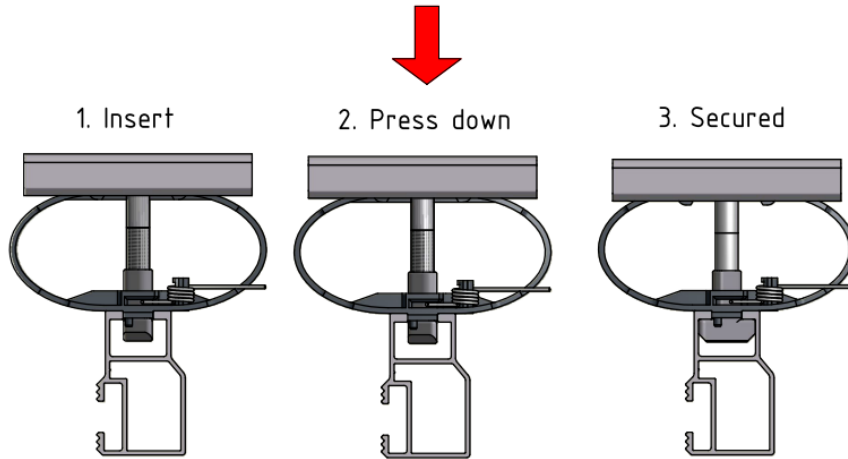


Figure 113: Inserting middle clamps G3

- The middle clamp G4 is swiveled into the carrier rail, where it is needed

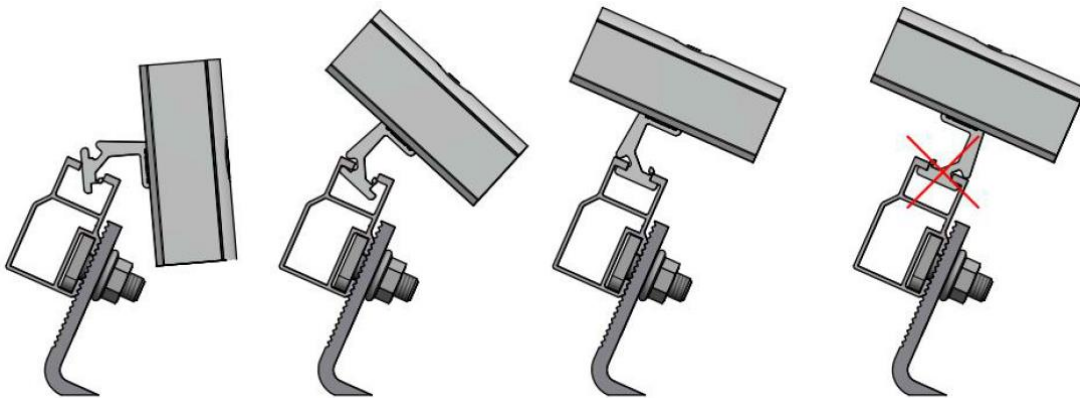


Figure 114: Inserting middle clamps G4



Important!

The slot nut of the G4 clamp must be aligned as shown in the **Figure 114** and must not be installed twisted.

- The adaptor EC is clamped by the given frame height with the middle clamp G4 and substitutes thus the outer clamp.

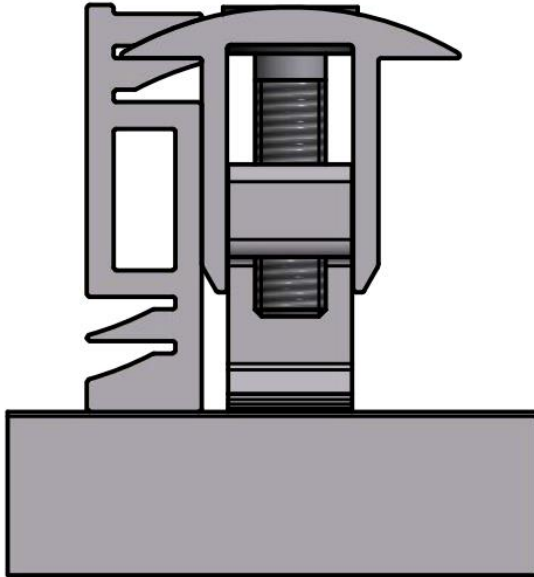


Figure 115: EC adapter with middle clamp G4

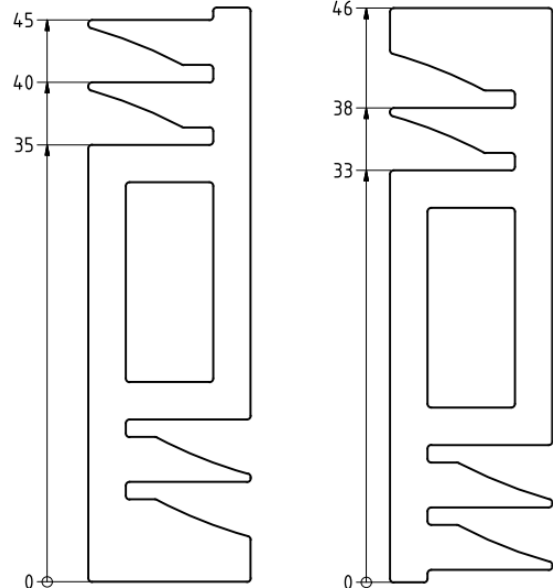


Figure 116: EC adapter frame heights

- Subsequently place the first module onto both carrier rails, loosely tighten it to the outside clamps respectively the middle clamp including EC adapter and align with the row of roof tiles. You may also use a piece of string to facilitate alignment. Then tighten the clamps to the tightening torque specified in Figure 165 in the Appendix. For this purpose, we recommend using a torque wrench with TX40 Torx bit size.
- Also tighten all remaining modules in this way. We recommend you start with the bottom row of modules. Assemble all other rows above once it has been exactly aligned.
- Please observe the specifications of the currently valid Z-14.4-660 building surveillance certificate.

07. Fitting cable clips

The cable clips are used to fix the module connector cables and prevent sagging of the cable. The clips can be clamped to the carrier rails of the mounting system TopFix 200 or to the photovoltaic module frames without any tools. Figure 117 shows the attachment of the cable clips 0° at the PV-module frame. In Figure 118 the cable clip is shown schematically 90° on a support profile.



Figure 117: cable clip 0° on module frame

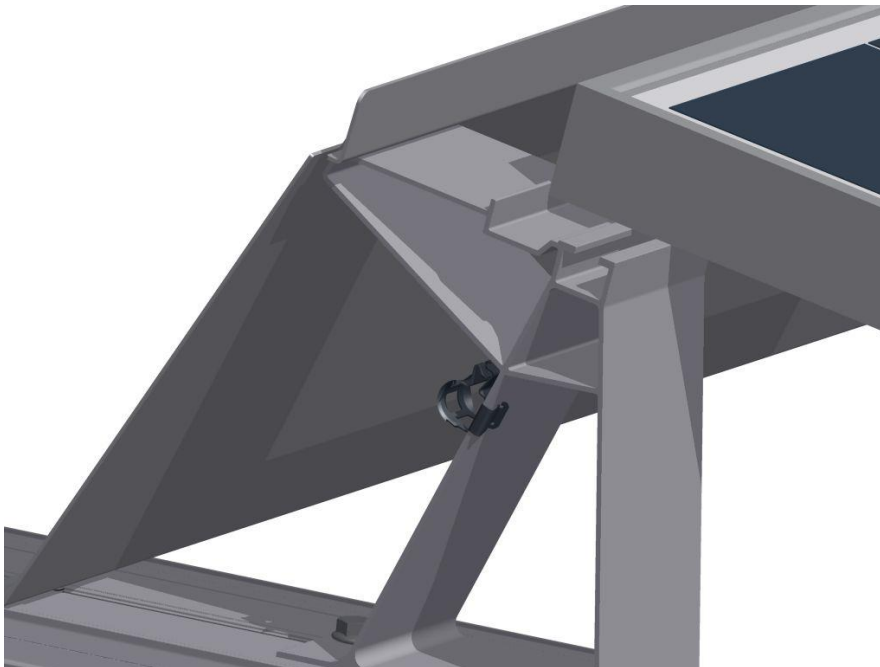


Figure 118: cable clip 90° on support profile

08. Fitting the two-layer carrier system

8.1 General information

In contrast to single-layer carrier rails, this method additionally employs carrier rails as so-called roof hook connecting rails before the actual carrier rail is fitted.

8.2 Type e.g. TF50+ roof hook connecting rails

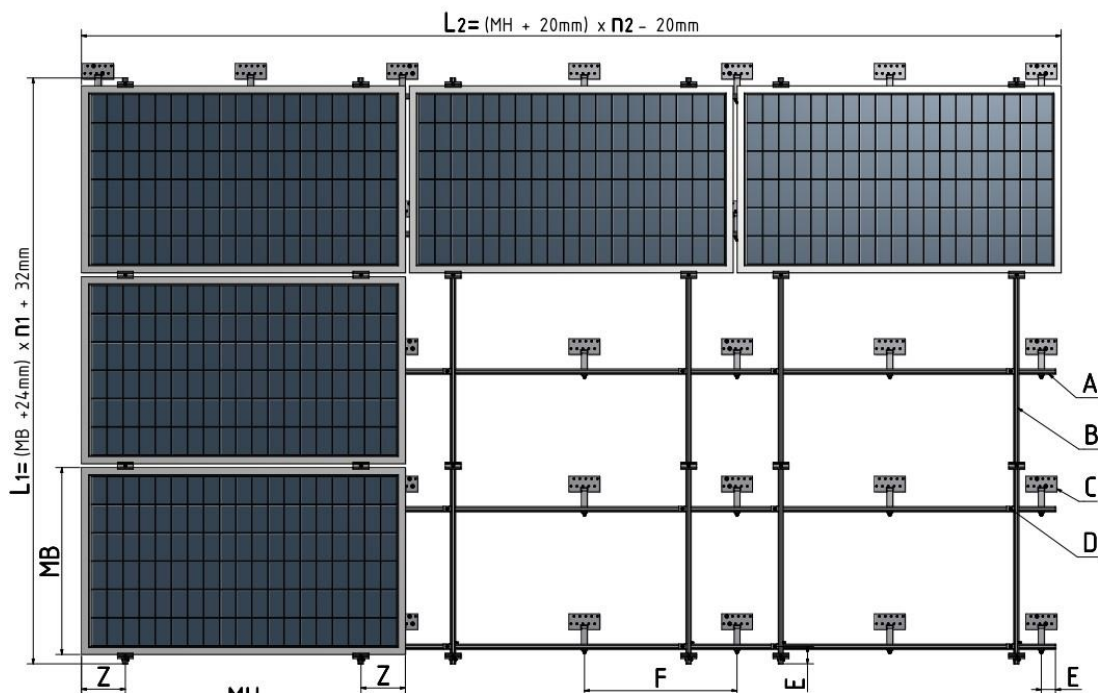


Figure 119: Roof hook connecting rails and carrier rails as a unit

	Description
$L = (MB + 24\text{ mm}) \times n + 32\text{ mm}$	Carrier rail length = (MB + 24 mm) × number of modules per row + 32 mm
$L2 = (MH + 20\text{ mm}) \times n2 - 20\text{ mm}$	Roof hook connecting rail length = (MH + 20 mm) × number of module rows – 20 mm
MB	Module width
MH	Module height
A	TF50+/TF50m/TF60 roof hook connecting rails
B	Type TF50+/TF50m/TF60 carrier rail

C	Roof hook
D	Two-layer connector
E	Max. 400mm
F	As per PV Manager
Z	Max. $\frac{1}{4}$ of the module height (please observe module manufacturer specifications)

Dimensioning:

Two-layer systems are dimensioned in the same way as single-layer systems. However, the following special features must be taken into account:

- Plan for one roof hook per area where carrier rail and roof hook connecting rail meet.
- Please also take into account the static values of roof hook connecting rails in addition to the roof hooks and carrier profiles. Use the PV Manager software to determine the static dimensions.
- We do not recommend you exceed a maximum carrier rail length of 3 rods (approximately 15,60 m) due to thermal expansion.

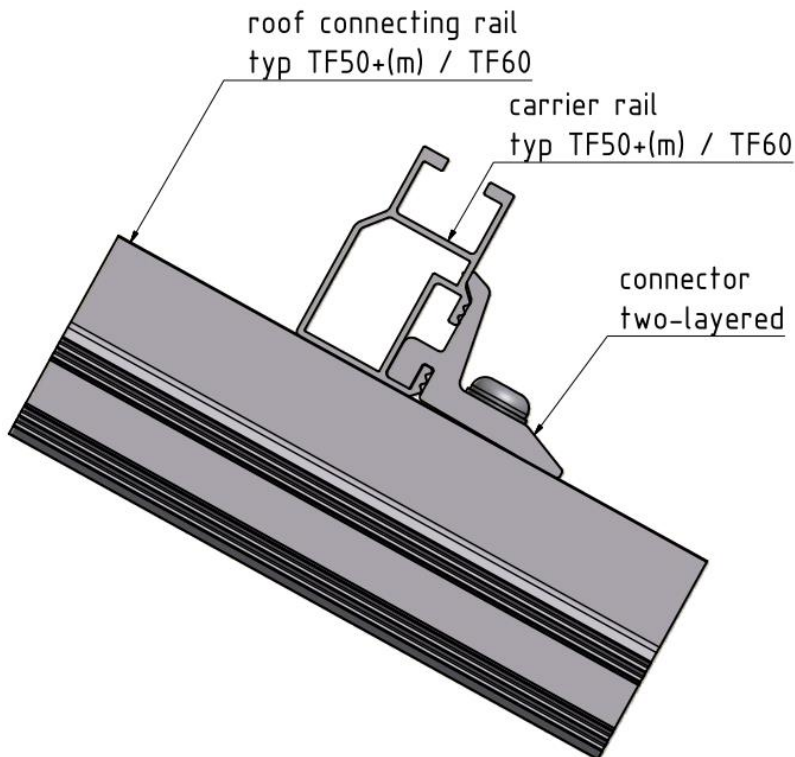


Figure 120: Cross section of a two-layer system structure

09. Delta support



Figure 121: Delta support

9.1 General information

Delta supports enable to use the IBC TopFix 200 mounting system as an elevated mounting system and achieve optimum module inclination.

Delta supports are available with single as well as continuous base rails. Inclination angles between 10° and 45° can be adjusted in 5° steps.

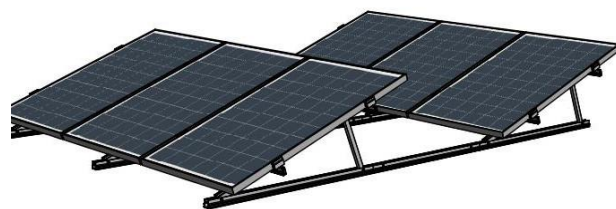


Figure 122: Delta support with single base rail

Figure 123: Delta support with continuous base rail

9.2 Assembly

Assembling Delta supports

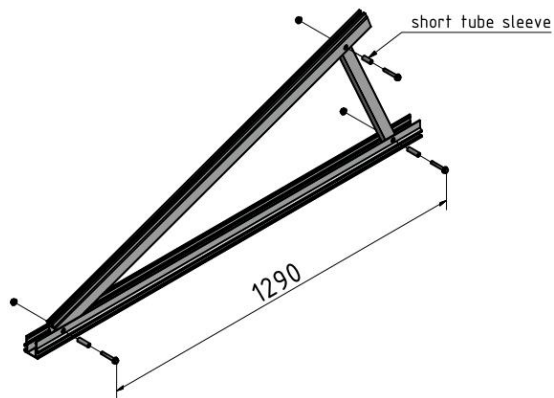


Figure 124: Assembling Delta supports at the base rails

Delta supports is supplied disassembled, including three M8×50 hex screws with self-locking nut and tube sleeves. When assembling, all screw connections must be tightened to 15 Nm.

Only by the Delta support with continuous base rail, the 12.5mm holes in the base rail must be drilled on site in the centering groove. The hole spacing within the Delta support is 1290mm. The row spacing is individually manufactured according to the project.

At the Delta support single the base rail is 1,5 m, at the Delta support continuous is the base rail 4,9 m long.

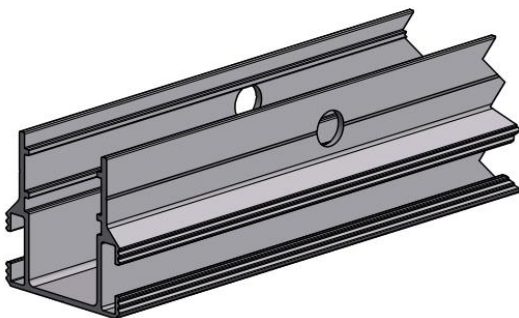


Figure 125: Centering groove for drilling

9.3 Connection to the roof

We offer the following connection types to connect Delta supports, depending on the available roof seal and roof substructure:

- Fixation by hanger bolt
- Fixation by universal connector
- Fixation by additional weight (e.g. positioning walkways, etc.)
- Fixation by trapezoidal clamps (two-layer connection with TF27)
- Fixation by roof hooks (single or two-layer connection)



Figure 126: Fixation by hanger bolt

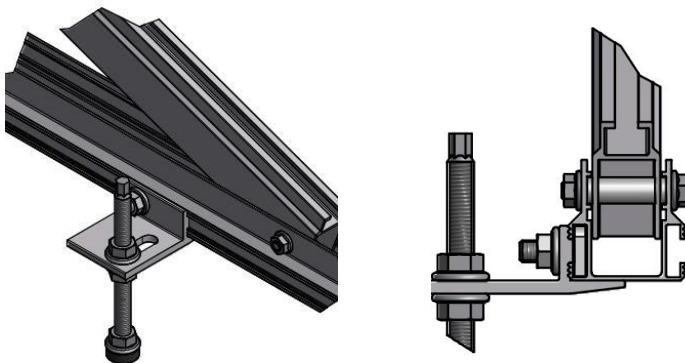


Figure 127: Fixation by universal connector

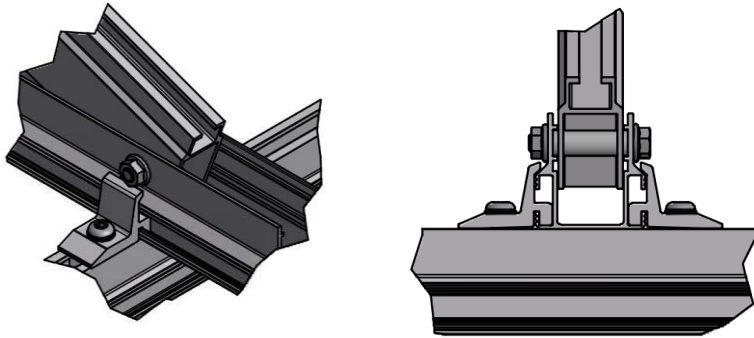
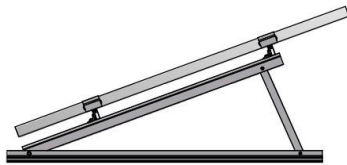


Figure 128: Two-layer fixation (two-layer connector)

9.4 Mounting modules

Modules can be mounted either horizontally or vertically using Delta supports. Modules up to a module size of 1.7 m can be suitable for vertical mounting.

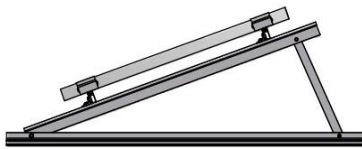
- Vertical module – clamps on the long sides



In this case, Delta supports are connected using two carrier rails (TF50+/TF50m/TF60). Modules are then mounted on said carrier rails.

Figure 129: Vertically mounted modules with module carrier rail

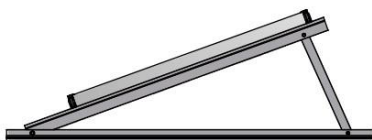
- Horizontal module – clamps on the short sides



In this case, Delta supports are connected using two carrier rails (TF50/TF50m/TF60). Modules are then mounted on said carrier rails. Please ensure that the modules have been approved for clamping on the short sides.

Figure 130: Horizontally mounted modules with module carrier profiles

- Horizontal module – clamps on the long sides



In this assembly process, modules are mounted directly on the Delta support. In this case, no further carrier rails are used. However, two Delta supports are required per module.

Figure 131: Horizontally mounted modules without module carrier rail

10. Insertion System

10.1 General

The same conditions and prerequisites apply as described in section 4.1 General dimensioning information. The insertion rail is always mounted horizontally. On tiled roofs the insertion system is built as a 2 layer system. Therefore, only roof hooks can be used where the roof connector rail can be mounted from ridge to eaves.

For a better water drainage $\leq \text{Ø}5$ mm holes may be drilled in the insertion rails. The load capacity of the insertion rail must not be affected.

10.2 System installation

Step 1: Dimensioning using "PV Manager"

Step 2: Roof hook

- Install roof hooks as described in section 4.2 Fitting the roof hooks, 4.4 ASD screws- Mounting on rafter-mounted insulation systems or 4.5 "Mammut Form S+" roof hook.

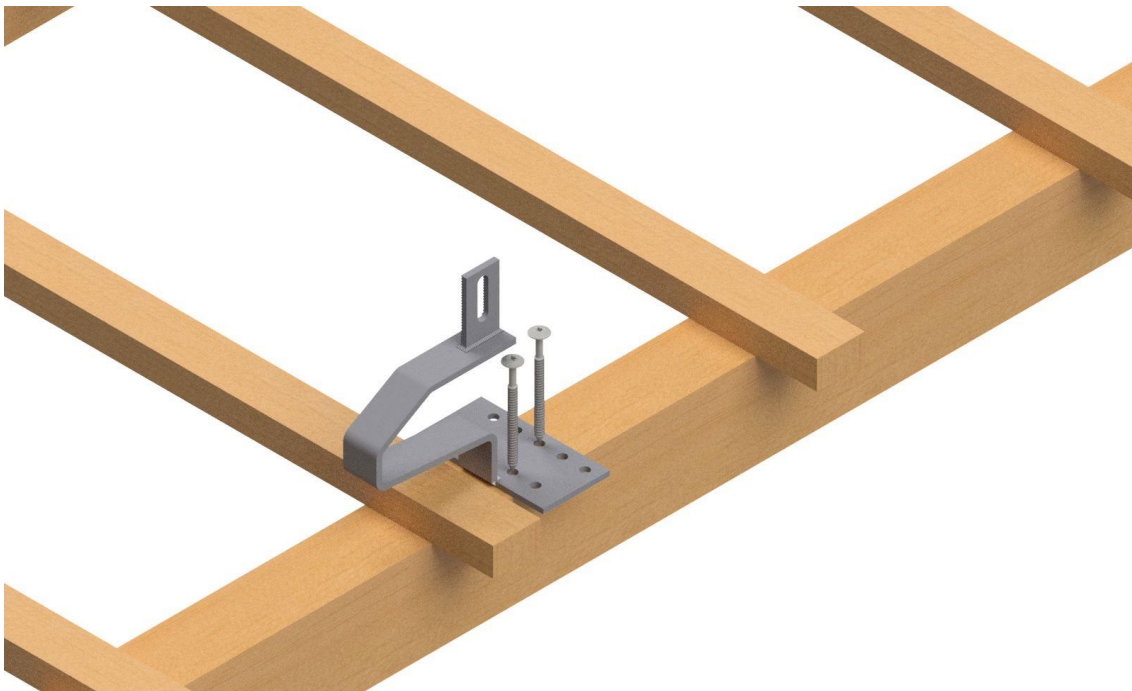


Figure 132: Example roof hook Mammut SV+

Step 3: Roof connector rail

- Mount and extend the profiles as shown in 05 Fitting carrier rails
- Align the other rails with each other by means of a cord.

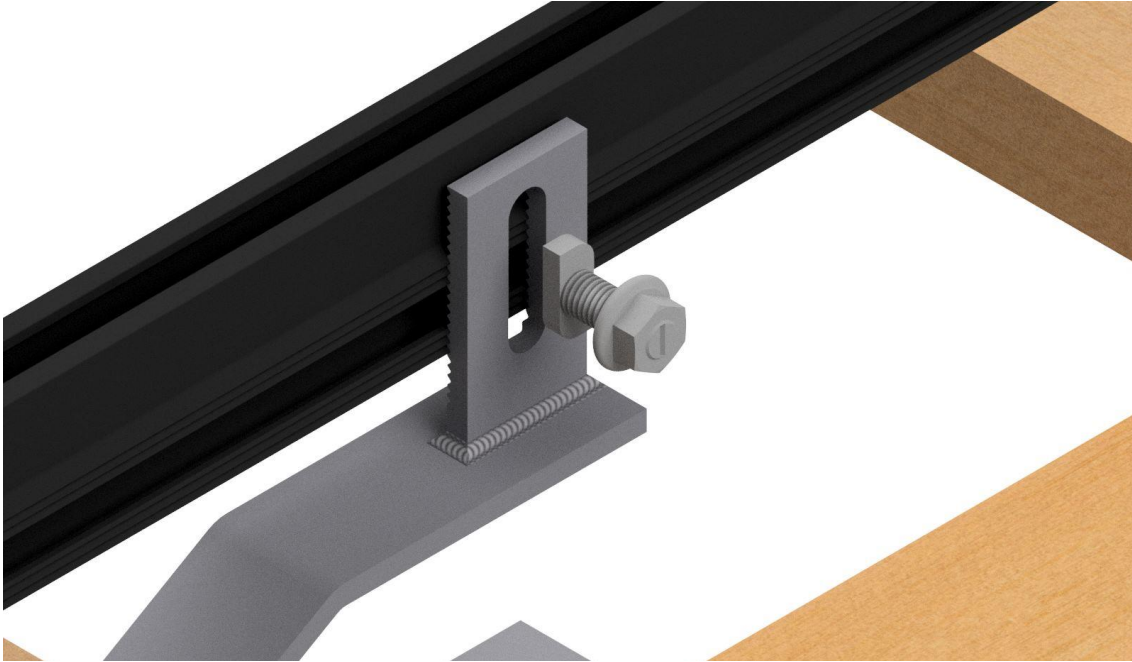


Figure 133: roof connector rail assembly



Figure 134: Butt connector for carrier rail TF50+

Step 4 Insertioen rail distances and assembly jig

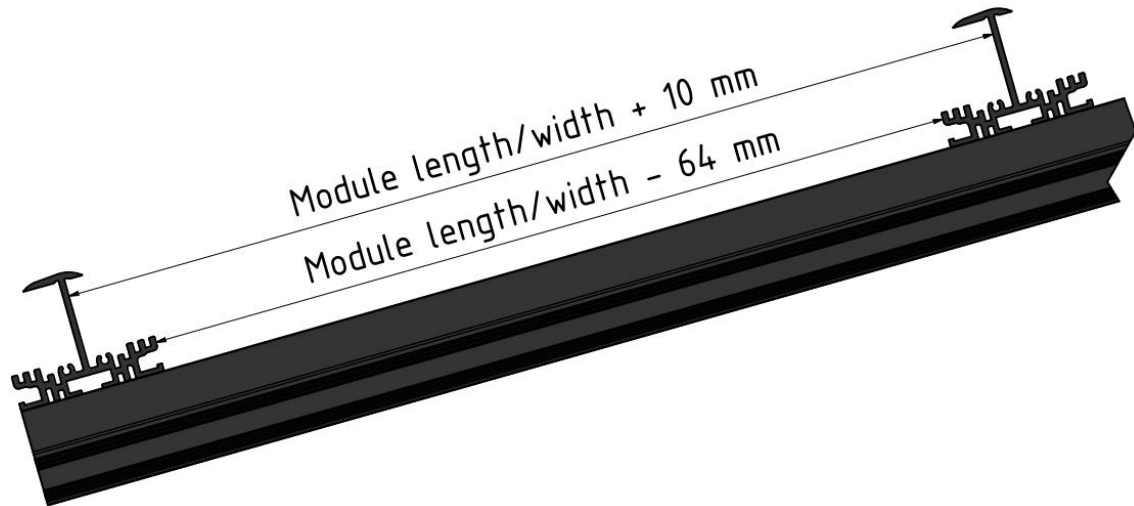


Figure 135: Insertion rails distance: Module length / -width + 10 mm, or module length / width - 64 mm

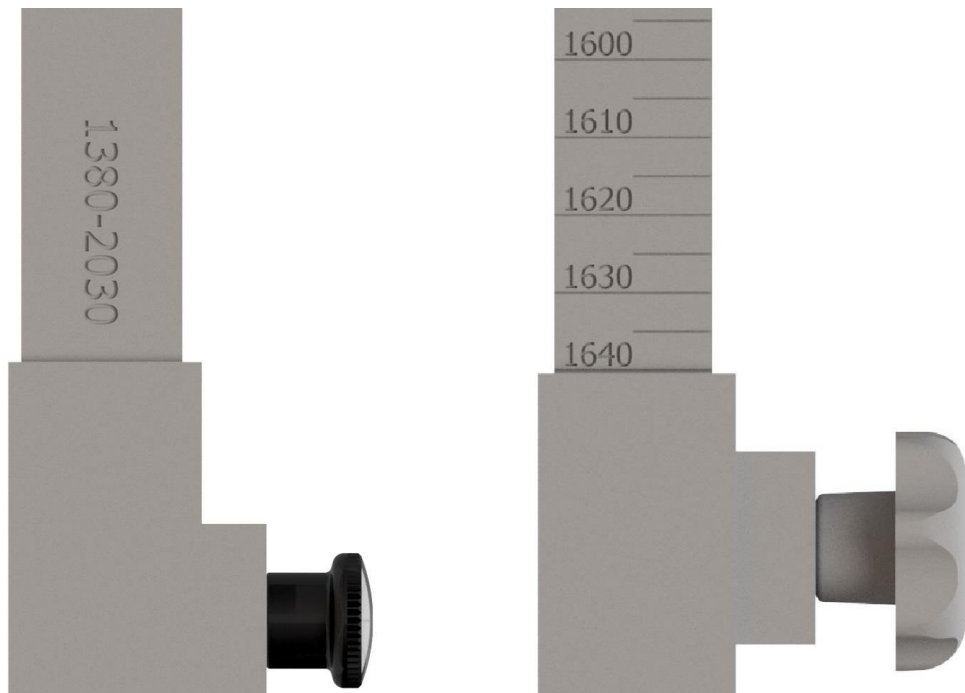


Figure 136: Adjusting the assembly jig

- The middle section of the assembly jig retracts at length 880 – 1530 mm and is extended at lengths of 1380 – 2030 mm.
- The module length or module width is adjusted by pulling out the end piece.



Important: The dimension set on the assembly jig does not correspond to the real length.



Figure 137: Positioned assembly jig

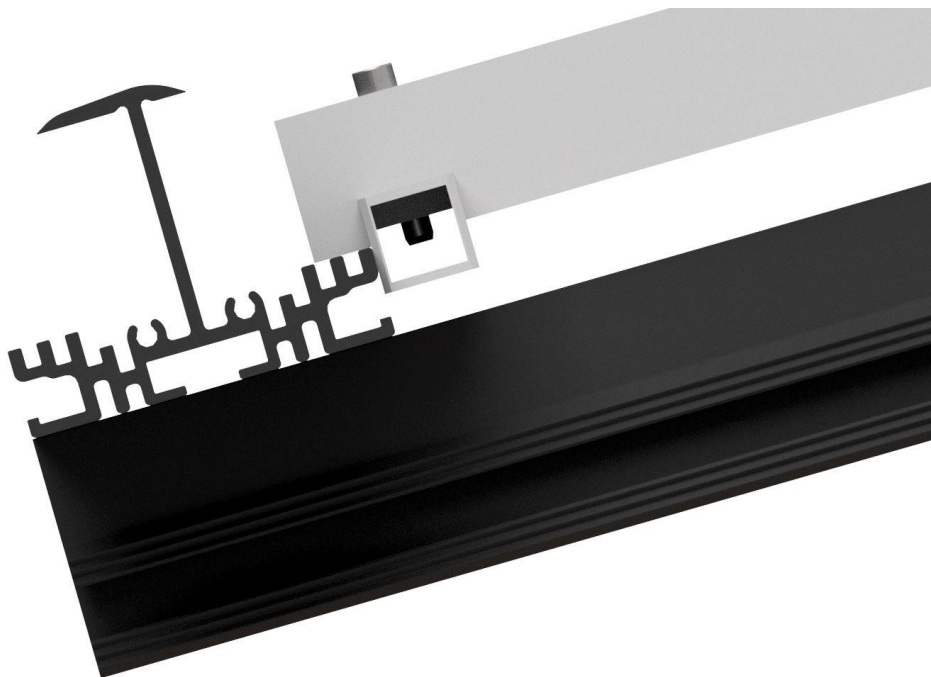


Figure 138: Detail position assembly jig bottom, analog top

Step 5 Two-layer connector

- The two-layer connector is mounted on the top and bottom insertion profile only on the inside. All other insertion profiles are fitted with a two-layer connector on both sides.

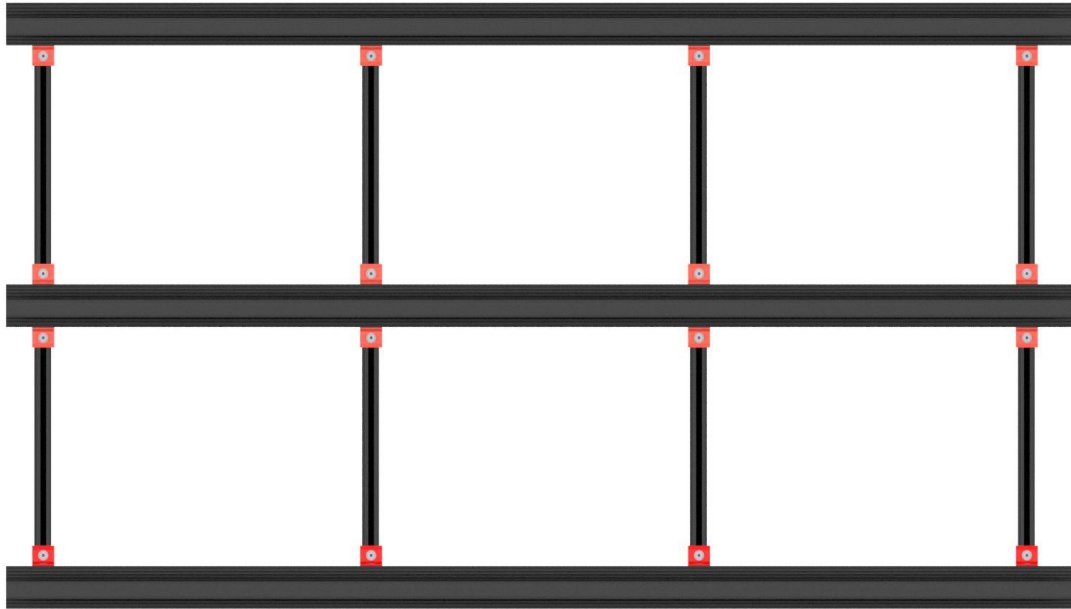


Figure 139: Position two-layer connector

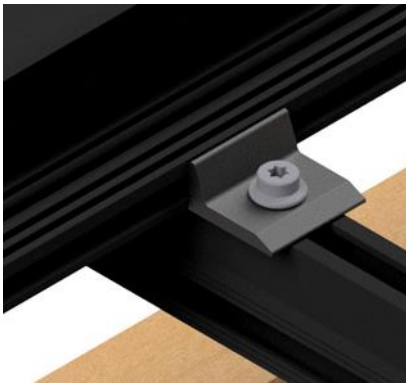


Figure 140: Two-layer connector

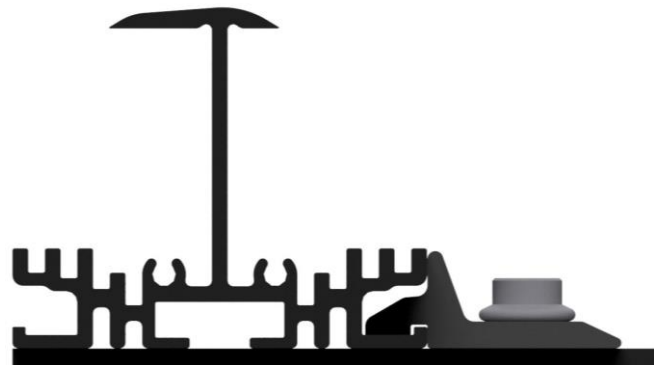


Figure 141: Side view two-layer connector

Step 6 Butt connector

- The butt connector is screwed from below with 4 t-head screws to the insertion rail.
- A small gap between the insertion rails can be left for a better water drainage.



Important!

Ensure that all t-head screws have turned in the rail and are therefore completely engaged. The insertion rail pieces must be fastened to at least two support points before a butt connector may be installed. Not more than one butt connector may be installed within two support points.

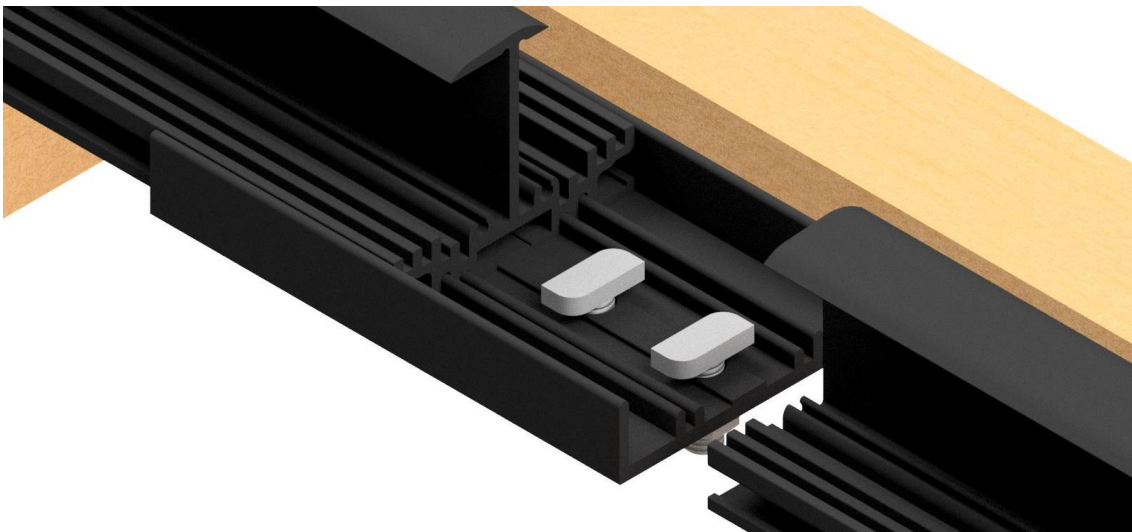


Figure 142: Butt connector insertion rail

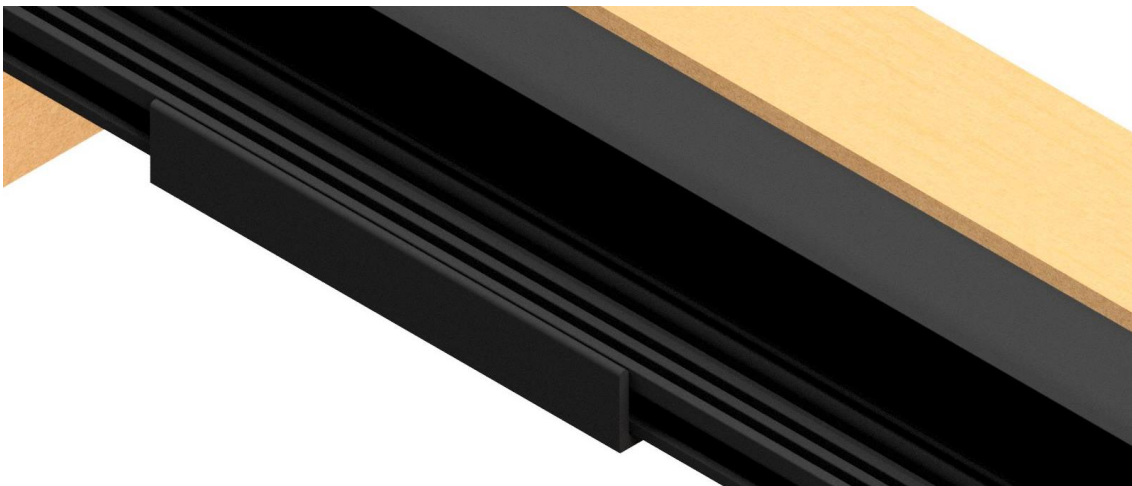


Figure 143: Mounted butt connector insertion rail

Step 7 Module frame height and adapter rail

- At 40 mm module frame height, no adapter rail is required
- The adapter rail is inserted into the insertion rail only at module frame heights of 38, 35, 33 and 32 mm at the corresponding position.

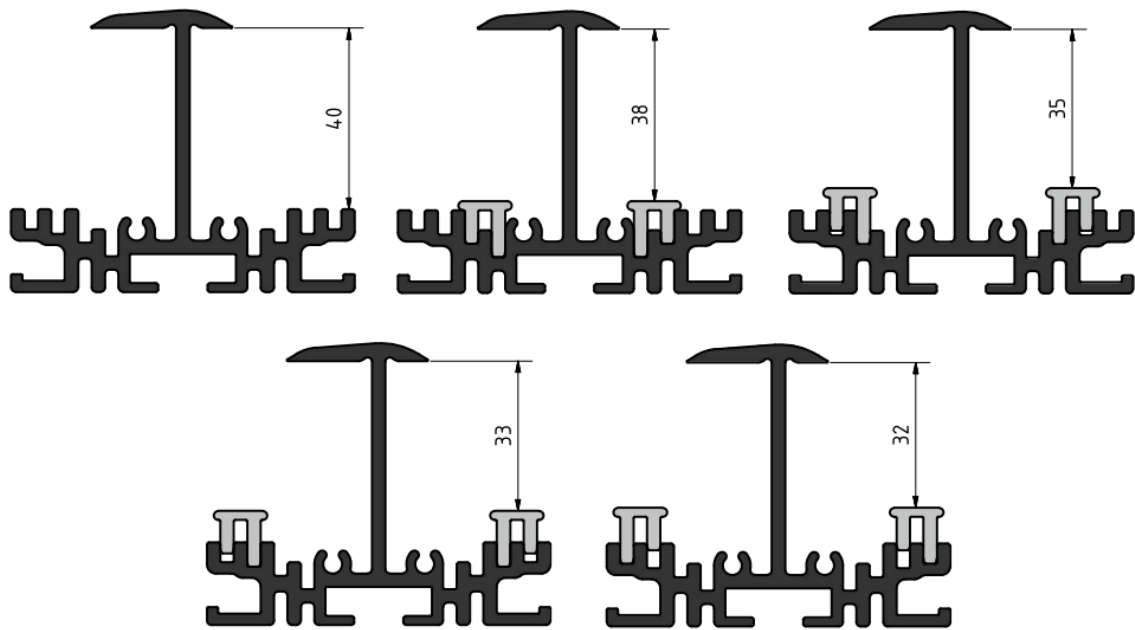


Figure 144: possible module frame heights



Figure 145: Insertion system adapter rail

Step 8 Insert module

- The modules are inserted diagonally into the upper insertion rail, placed on the lower insertion rail and pushed down to the stop.

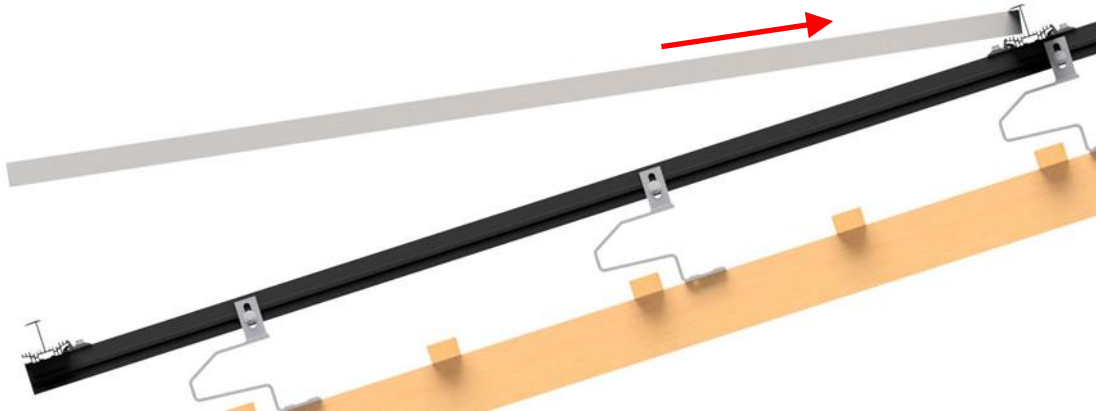


Figure 146: Insert module



Figure 147: Put down module

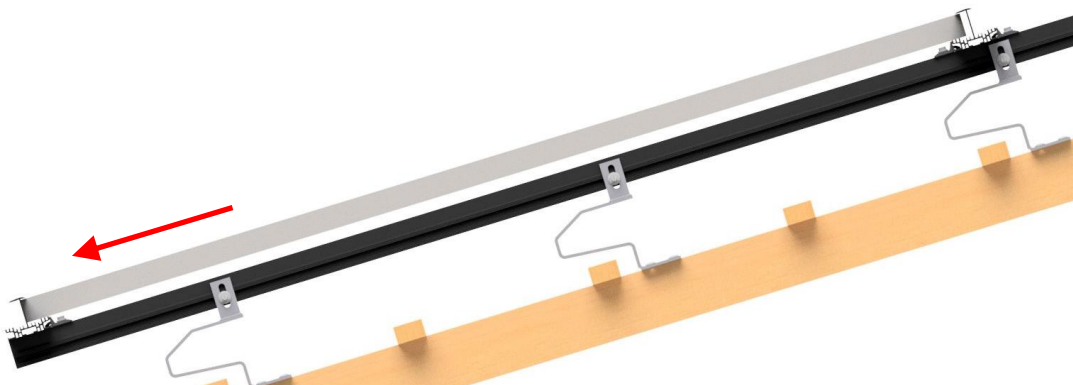


Figure 148: Slide module into position

Step 9 Spacer / protection against theft

- The spacer is inserted at the top between the module and the insertion rail
- A ratting of the modules by wind is prevented, because the modules are easily clamped.
- An illegal removal of the modules is prevented.
- Note the gap between the modules in module installation manual. 10 mm gap for IBC modules is maintained.
- If the roof pitch is $<15^\circ$, the spacer must be installed.

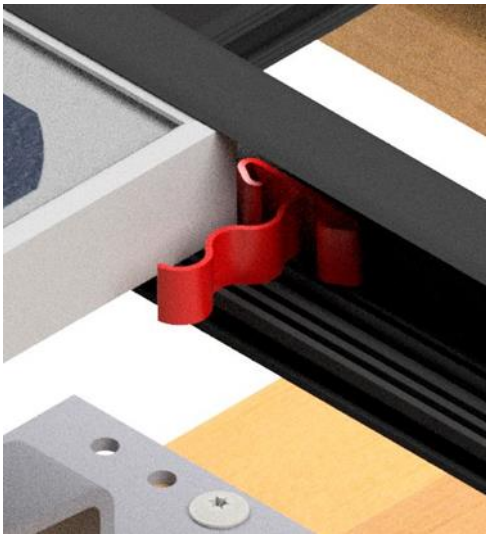


Figure 149: Attach spacer

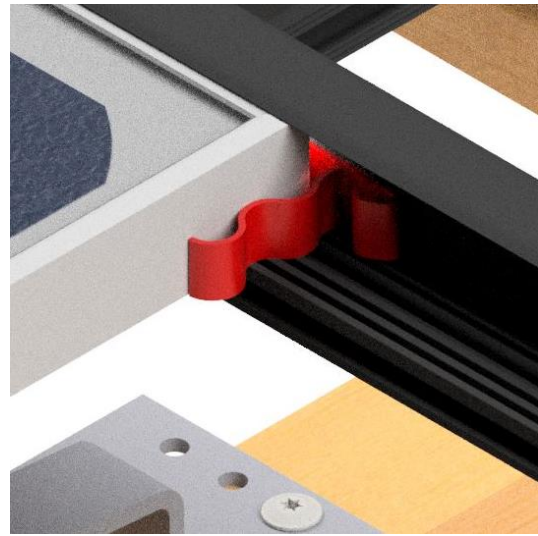


Figure 150: Insert spacer

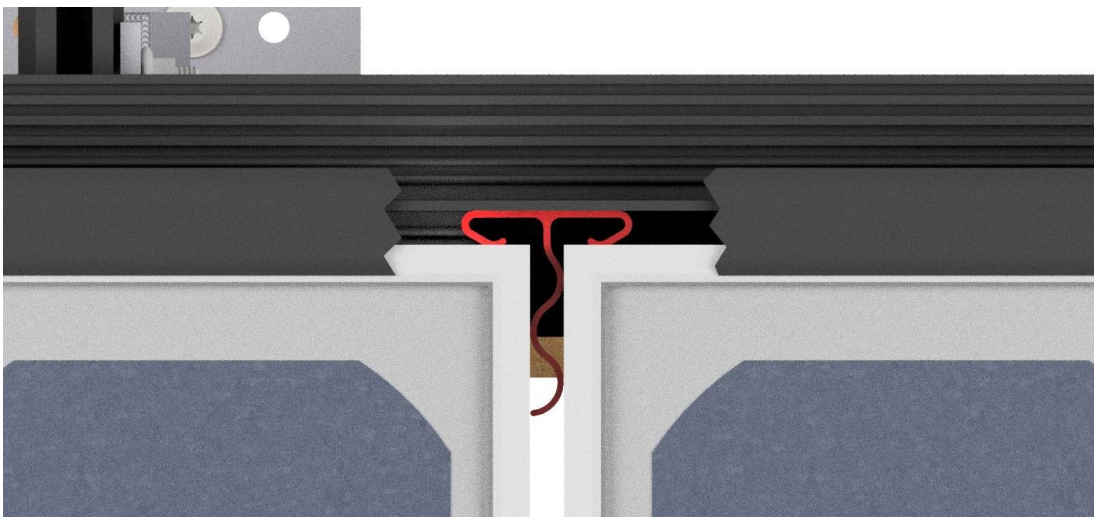


Figure 151: Mounted spacer

Step 10 Side plate

- The side plate is fixed to the insertion rail with 2 sheet metal screws 4.8x19.
- Holes in the side plate allow a drainage of water

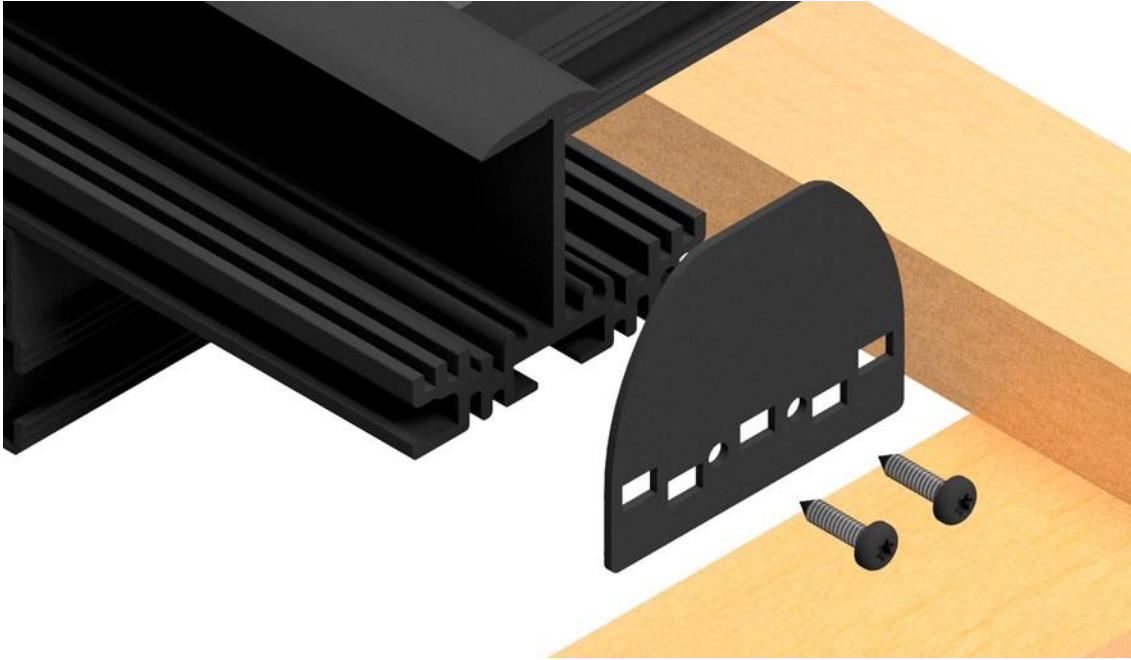


Figure 152: Side plate



Figure 153: Mounted side plate

Step 9 End cover

- The end cover is clicked into the top and bottom insertion rail. If modules are missing within the module field, end covers are also installed here.

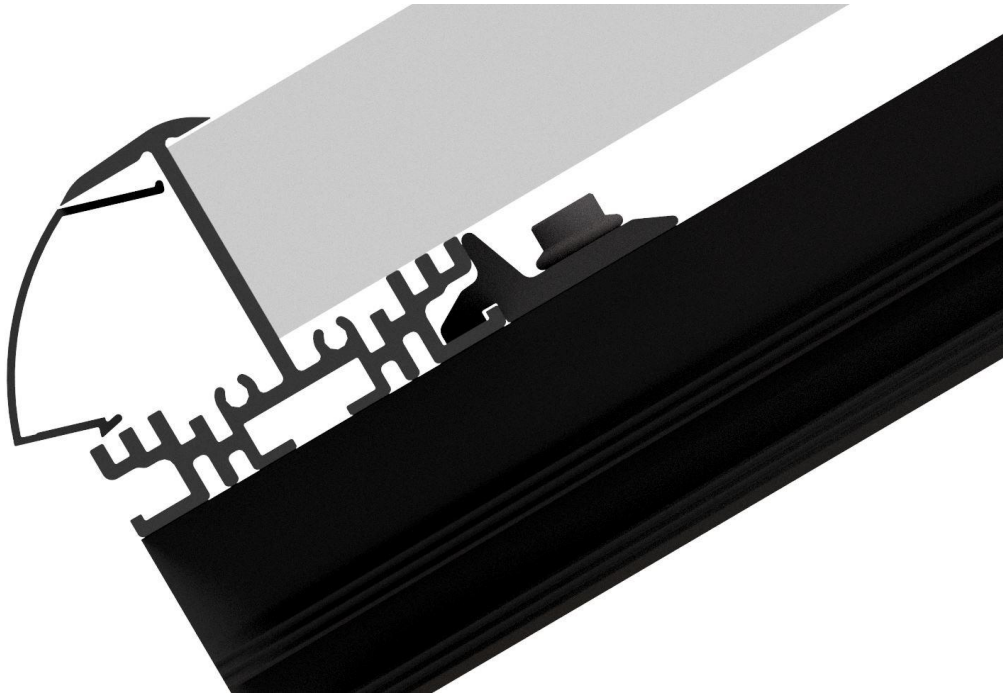


Figure 154: Attach the end cover and click in

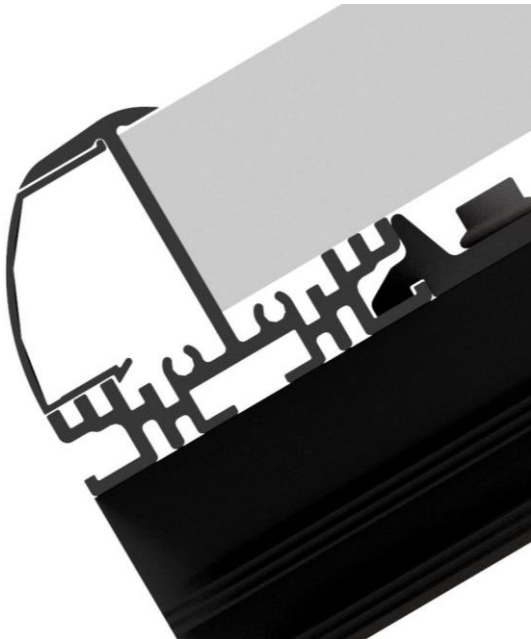


Figure 155: Mounted end cover at the bottom

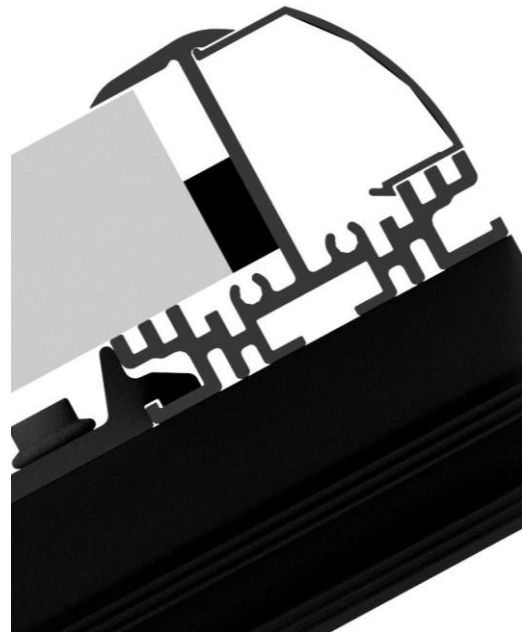


Figure 156: Mounted end cover at the top

11. IBC FrameFix module frame reinforcements

10.3 General information

We recommend retrofitting IBC FrameFix frame reinforcements in regions with a high degree of snow loads. A high degree of snow loads on vertically mounted modules may deform the frame and hence render the module unusable.

IBC FrameFix counteracts this and reinforces the frame from the rear. The structure is not visible and it does affect the mounting system.

- Frame reinforcement for large-scale, vertically mounted PV modules (48, 60 and 72 cells)
- For module frame dimensions (with adapter) (length/width/height):
 - 1660-1680 mm/990 mm/40–50 mm
(1640-1659 mm/ ca. 990 mm/ 40-50 mm)
 - 1580-1620 mm/ 800 mm/40-50 mm
 - 1310-1340 mm/990 mm/40-50 mm
- Cable capacity up to 8 kN (800 kg)
- Mounting in a few simple steps
- Module frame not affected by additional drilling
- In the event of subsequent repairs to the PV generator it is merely required to remove the module, not the entire mounting system

10.4 Assembly

- If necessary, insert the adapter on the cable from the clamping shoe.
- Insert FrameFix corner bracket into the module frame from the rear
- Align the cable structure
- Pull the tensioning piece over the frame
- Pre-tighten FrameFix to 5 Nm



Important!

Prevent advance frame deformation caused by FrameFix.



Figure 157: Assembled FrameFix



Figure 158: Corner bracket



Figure 159: Tensioning piece

10.5 Assembling adapter

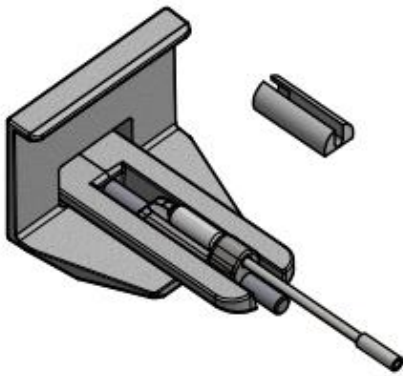


Figure 160: Tensioning piece and adapter

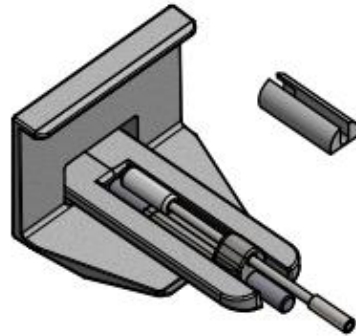


Figure 161: Disconnect the cable from the tensioning piece

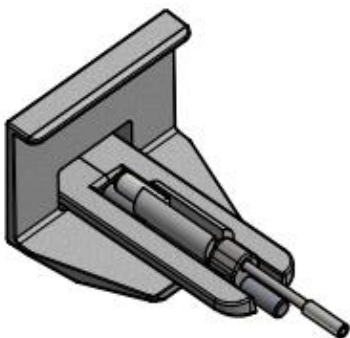


Figure 162: Insert the adapter under the cable

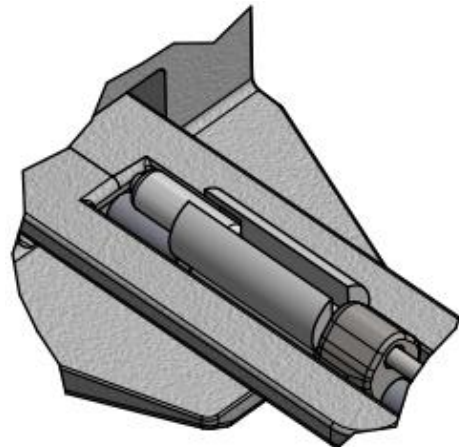


Figure 163: Adapter mounted

12. Bill of materials

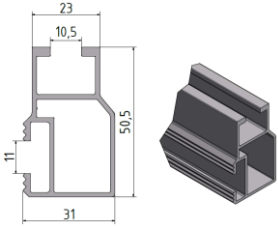
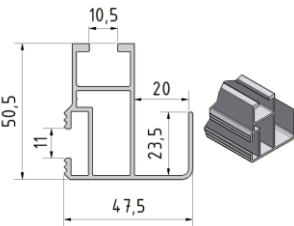
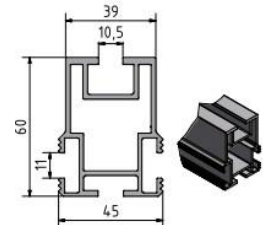
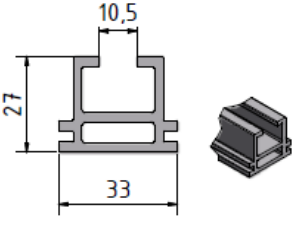
Illustration	Item no.:	Item
	6800100022	Support Rail TF50+, 5200mm
	6800100023	Support Rail TF50+, 3100mm
	6800100027	Support Rail TF50+, 2100mm
	6800100033	Support Rail TF50+, 5200mm black
	6800100019	Support Rail TF50m, 5200mm
	6800100028	Support rail TF50m, 2100mm
	6800100020	Support Rail TF60, 5200mm
	6800100029	Support Rail TF60, 2100mm
	6800100021	Support Rail TF27-T, 5200mm
	6800100015	Support Rail TF27-T, 3100mm
	6800100030	Support Rail TF27-T, 2100mm

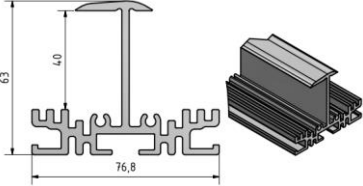
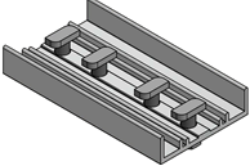
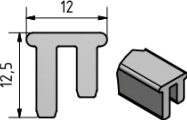
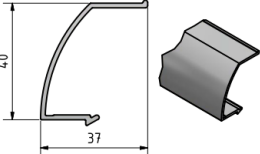
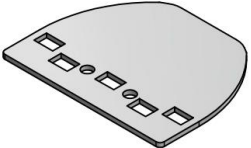
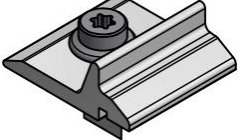
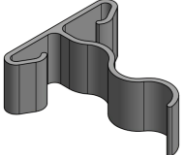

Illustration	Item no.:	Item
	6800100034	Insertion Rail, 5010mm black
	6800100038	Insertion Rail, 2010mm black
	6700300064	Butt Connector Insertion Rail black
	6800100035	Adapter Rail, 2100mm
	6800100036	End Cover, 2010mm black
	6700200051	Side Plate black
	6700300063	Two-Layer Connector black
	6700200052	Spacer black
	6900600012	Drilling screw 4,8x19 DIN7981

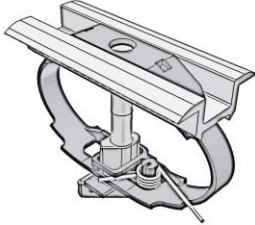
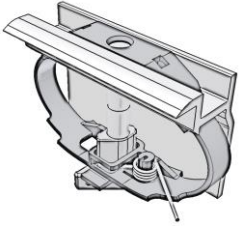
Illustration	Item no.:	Item
		IBC TopFix 200 middle clamp G3
	6700400125	Middle Clamp G3 30-50mm
	6700400126	Middle Clamp G3 30-50mm, black
		IBC TopFix 200 outside clamp G3
	6700400127	End clamp G3 31 mm
	6700400128	End clamp G3 31 mm black
	6700400165	End clamp G3 32mm
	6700400166	End clamp G3 32mm black
	6700400129	End clamp G3 33 mm
	6700400169	End clamp G3 33 mm black
	6700400130	End clamp G3 35mm
	6700400131	End clamp G3 35 mm black
	6700400132	End clamp G3 38 mm
	6700400133	End clamp G3 38 mm black
	6700400134	End clamp G3 40 mm
	6700400135	End clamp G3 40 mm black
	6700400136	End clamp G3 42 mm
	6700400137	End clamp G3 42 mm black
	6700400138	End clamp G3 45 mm
	6700400139	End clamp G3 45 mm black
	6700400140	End clamp G3 46 mm
	6700400141	End clamp G3 46mm black
	6700400142	End clamp G3 50 mm
6700400143	End clamp G3 50 mm black	

Illustration	Item no.:	Item
	6700400144	Middle clamp G4 33-46mm
	6700400145	Middle clamp G4 33-46mm black
	6700400161	EC adapter 33-46mm
	6700400162	EC adapter 33-46mm black
	6700100026	"Standard S+" roof hook
	6700100032	"Standard S+, 35mm" roof hook
	6700100027	"Mammut S+" roof hook

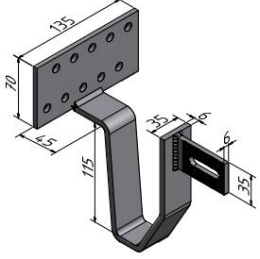
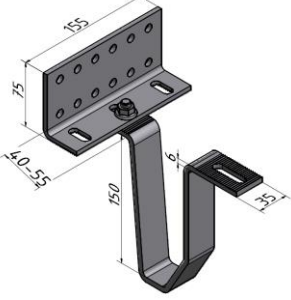
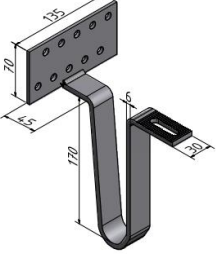
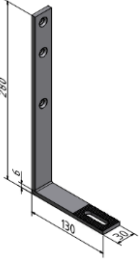
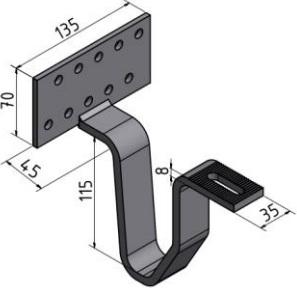
Illustration	Item no.:	Item
	6700100028	"Mammut SV+" roof hook
	6700100029	"Vario S+" roof hook
	6700100030	"Biber S+" plain tile roof hook
	6700100031	"Schiefer S+" slate tile roof hook
	6700100041	Mammut XL S+ roof hook


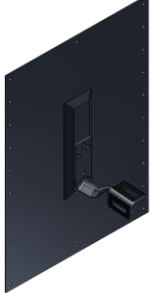
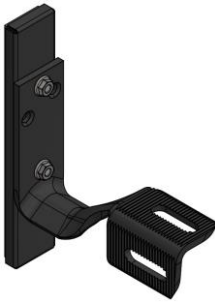

Illustration	Item no.:	Item
	<p>6700700022- 6700700040 & 6700700042- 6700700097</p>	<p>"Mammut Form S+" roof hook</p> <p>Includes: 1x roof hook with sheet metal tile 1x reinforcing runner 3x 4.2x32 mm drilling screw (tallow-drop screw, galvanised, AW 20) 1x 5.0x120 mm drilling screw (self-tapping, countersunk screw, galvanised, AW 20 type 2) 2x 5.0x60 mm drilling screw (self-tapping screw, A2 stainless steel, AW 20 type 2)</p> <p>For available types see "Mammut Form S+" leaflet</p>
	<p>6700700021</p>	<p>"Mammut Form S+" roof hook for bitumen roofs</p> <p>Includes: 1x roof hook with sheet metal tile 8x 4.8x32 mm drilling screw (tallow-drop screw, galvanised, AW 25) 2x 4.8x60 mm drilling screw (tallow-drop screw, galvanised, AW 25)</p>
	<p>6700700041</p>	<p>"Mammut Form S+" roof hook</p> <p>For slate & metal shingle</p> <p>Includes: 1x roof hook 1x mounting plate with seal 1x cover cap 3x wood screw 8 x 140 mm 2 St. nuts M6</p>
	<p>6700100036</p>	<p>"Alu-Vario S+" roof hook</p>

Illustration	Item no.:	Item
	6700100038	“Alu-Mammut S+” roof hook
	6700100039	“Alu-Mammut SV+” roof hook
	6700200036	Trapezoidal sheet clamp Without accessories
	6700200037	ECO trapezoidal system, 340 mm Without accessories
	6700200038	ECO trapezoidal system, 420 mm Without accessories



Illustration	Item no.:	Item
	6700200041	Hanger bolt M12x300 A2 SW9 Including 1x EPDM seal 3x M12 A2 self-locking nuts → completely pre-assembled
	6700200045	Hanger bolt M12x250 A2 SW9 Including 1x EPDM seal 3x M12 A2 self-locking nuts → completely pre-assembled
	6700200026	Hanger bolt M10x200 A2 SW7 Including 1x EPDM seal 3x M10 A2 self-locking nuts → completely pre-assembled
	6700200018	Solar fastener 8/M10x80/50 Including bell-type seal and nuts, pre-assembled
	6700200019	Solar fastener 8/M10x100/50 Including bell-type seal and nuts, pre-assembled
	6700200020	Solar fastener 8/M10x125/50 Including bell-type seal and nuts, pre-assembled
	6700200021	Solar fastener 8/M10x150/50 Including bell-type seal and nuts, pre-assembled
	6700200022	Solar fastener 8/M10x160/50 Including bell-type seal and nuts, pre-assembled
	6700200023	Solar fastener 8/M10x200/50 Including bell-type seal and nuts, pre-assembled

Illustration	Item no.:	Item
	6700300050	Mounting plate duo TopFix 200 Including screws + universal connector
	6700300051	Mounting plate duo TopFix 200 Including Connecting Connection Piece M10
	6700200049	Universal Metal Seam Clamp G2
	6700200027	Original Kalzip® clamp Including universal connector
	6700300003	Module fixing bracket
	6101100027	Cable clip 0°
	6101100028	Cable clip 90°



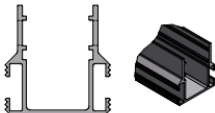
Illustration	Item no.:	Item
		Delta support, single
	6100300024	Delta support, 10°, single
	6100300025	Delta support, 15°, single
	6100300026	Delta support, 20°, single
	6100300027	Delta support, 25°, single
	6100300028	Delta support, 30°, single
	6100300029	Delta support, 35°, single
	6100300030	Delta support, 40°, single
6100300031	Delta support, 45°, single	
		Delta support, continuous without base rail
	6100300032	Delta support, 10°, continuous
	6100300033	Delta support, 15°, continuous
	6100300034	Delta support, 20°, continuous
	6100300035	Delta support, 25°, continuous
	6100300036	Delta support, 30°, continuous
	6100300037	Delta support, 35°, continuous
	6100300038	Delta support, 40°, continuous
6100300039	Delta support, 45°, continuous	
	6800900014	Base rail D-S (uncut length L = 4900 mm)

Illustration	Item no.:	Item
	6700300046	Butt connector TF50+ / TF50-m Including 2x M10x25 A2 T-head screws 2x DIN 6923 M10 A4 locking nuts -> completely pre-assembled
	6700300044	Butt connector TF60 Including 2x M10x25 A2 T-head screws 2x DIN 6923 M10 A4 locking nuts
	6700300058	Butt connector TF27-T Without accessories
	6700300047	Butt Connector Base Rail D-S Including 2x M10x25 A2 T-head screws 2x DIN 6923 M10 A4 locking nuts
	6700300059	Positive-Locking-Clamp Set Without accessories
	6700300035	Universal connector Including 1x M10x35 A2 T-head screw 1x M10 A4 locking nut -> completely pre-assembled
	6700300037	Two-layer connector

Illustration	Item no.:	Item
	6700300041	Rail end cap for TF50+ and TF50m
	6700300061	Rail end cap black for TF50+ and TF50m
	6700300045	Rail end cap for TF60
	6900300007	Flange Head Screw 6x100 A2
	6900300008	Flange Head Screw 8 x 100 A2
	6900300010	Flange Head Screw 8 x 140 A2
	6900300011	Countersunk screw 8x 100 A2
	6900300012	Flange Head Screw 8x 40 A2
	6900300014	ASD Flange Head Screw 8x240 A2 With thread under the screw head
	6900300015	ASD Flange Head Screw 8x300 A2 With thread under the screw head

Illustration	Item no.:	Item
	6900300016	ASD countersunk screw 8x280
	6900300017	ASD countersunk screw 8x340
	6908300003	Blind Rivet 4.8x15 PU 100
	6900600011	Self-Drilling-Screw 5.5x25 PU 100
	6700300032	Connection Piece M10 For roof hooks
	6700300053	Connection Piece M8 For roof hooks
	6700300033	Universal Connection Piece
	6700200013	Clamp for equipotential bonding
	6700300042	FrameFix, 60 cell unit, 6"
	6700300049	FrameFix, 48 cell unit, 6"
	6700300052	FrameFix, 72 cell unit, 5"

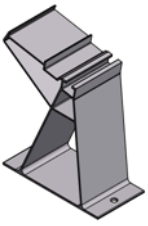
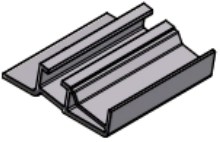

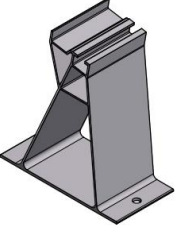
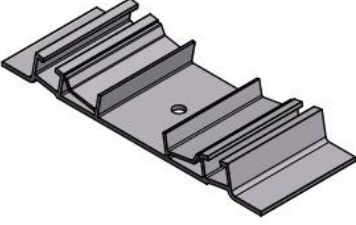
Illustration	Item no.:	Item
AeroFix 10-S		
	6101100042	Top Support Also used in AeroFix 10-EW with wind plate beginning and ending.
	6101100043	Bottom Support Also used in AeroFix 10-EW with module beginning and ending.
	6101100016	Wind plate Also used in AeroFix 10-EW with wind plate beginning and ending.
AeroFix 10-EW		
	6101100044	Top Support Without windplate mounting
	6101100045	Bottom Support

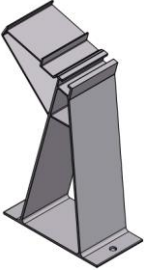
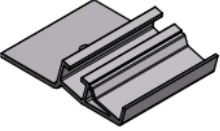
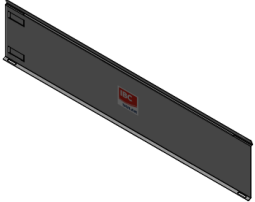
Illustration	Item no.:	Item
AeroFix 15-S		
	6101100046	Top Support
	6101100047	Bottom Support
	6101100019	Wind plate

Figure 164 Bill of materials

13. Appendix

12.1 Notes on IBC TopFix 200

Tightening torques for screw connections

The tightening torques for the screw connections used in the IBC TopFix200 mounting system must be dimensioned in accordance with DIN ISO 3506, to document and archive for 10 years. Due to the difficulty in determining the outdoor friction coefficients, dimensioning in accordance with DIN ISO 3506 can prove difficult.

We therefore recommend the following tightening torques:

Screw connection	Tightening torque
M8	15 Nm
M8 connection piece for roof hook-profile	30 Nm
M10	30 Nm

Figure 165: Pre-tension for screws

We do not recommend using a wrench as this may quickly cause you to exceed the tightening torque. It is sufficient to use a torque wrench or a hex spanner with T-grip.



Important!

When using laminate clamps, please clarify the tightening torque for the corresponding assembly situation with the laminate manufacturer.

Required rafter and purlin dimensions

Comply with the following minimum dimensions for rafters and purlins as per EN 1995-1-1.

structural element	stress	title edge distance		diameter d [mm]	miniumum depth [mm]	minimum dimension width "b" [mm] (pre-drilled)	edge distances			
							not pre-drilled	pre-drilled		
		1	type of wood				$p_k < 420 \text{ kg/m}^3$	$420 \text{ kg/m}^3 < p_k < 500 \text{ kg/m}^3$	$p_k > 500 \text{ kg/m}^3$	
		2	formula		$4 \times d$	$2 \times a_{2,c} + 15 \text{ mm}^*$	soft wood - solid wood C24 - C40 laminated timber GL24 - GL28 and GL32c	laminated timber GL32h, GL36	hard wood - solid wood D30 - D60	
rafter	vertical (roof hook)	3	unstressed edge	$a_{2,c}$	6	24 mm	51 mm	$a_{2,c} = 5 \times d$	$a_{2,c} = 7 \times d$	$a_{2,c} = 3 \times d$
		8		32 mm	63 mm	30 mm	42 mm	18 mm		
		10		40 mm	75 mm	40 mm	56 mm	24 mm		
		4	formula		$4 \times d$	$a_{2,t} + a_{2,c}$	$a_{2,t} = (5 + 5 \times \sin \alpha) \times d$	$a_{2,t} = (7 + 5 \times \sin \alpha) \times d$	$a_{2,t} = (3 + 4 \times \sin \alpha) \times d$	
purlin	horizontal (hanger bolt)	5	stressed edge	$a_{2,t}$	6	24 mm	60 mm	60 mm	72 mm	42 mm
		8		32 mm	80 mm	80 mm	96 mm	56 mm		
		10		40 mm	100 mm	100 mm	120 mm	70 mm		
		12		48 mm	120 mm	120 mm	144 mm	84 mm		

*] 15 mm = center distance between flat head screws
 α angle between direction of force and direction of fiber (purlins 90°)
 pre-drill with $0,7 \times d$

Figure 166: Minimum distance and required timber component dimensions

The minimum rafter/purlin height must be 100 mm.

The minimum distance between fastened flat head screws and the edges of rafters and purlins must be three times the flat head screw diameter. Position hanger bolts in the centre of rafters and outside the centre on purlins.

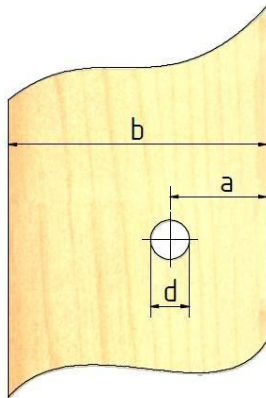


Figure 167: Defining the distance to the edge of rafters

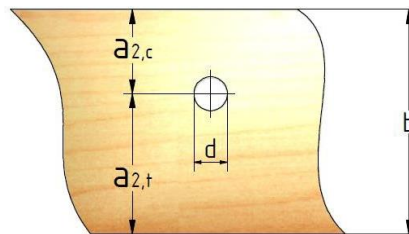


Figure 168: Defining the distance to the edge of purlins

12.2 Weights/installation times for pitched roof installations

	Weight per m ² of module surface	Weight per kWp
Thin-film solar modules	10 ... 17 kg/m ²	130 ... 300 kg/kWp
Crystalline solar modules	11 ... 21 kg/m ²	70 ... 175 kg/kWp
Single-layer mounting system	*2.4 ... 5 kg/m ²	*18 ... 35 kg/kWp
Two-layer mounting system	*5 ... 7 kg/m ²	*35 ... 50 kg/kWp

* Values are based on crystalline solar modules, the weight of the mounting system increases with thin-film solar modules.

Installation times:

It will take two installers approximately 1-2 hours to install a PV system with an output of 1 kWp (under normal conditions).

All specified values are theoretical values. In practical application, installation times and weights may vary, depending on the system version. Weights and installation times for DC cabling, ground and lightning protection have not been taken into account.

12.3 Notes on maintenance

The IBC TopFix 200 mounting system is largely maintenance-free thanks to the materials used.

In addition to the electrical inspections prescribed for the entire PV system, we recommend an annual and event-dependent (heavy storm, hail etc.) inspections of the mounting system into account the points of the maintenance log.

Disassembly of the mounting system is carried out in the reverse order of assembly steps.

If it becomes necessary to clean the modules, this must be done without chemical cleaning products and using clear water only.

The modules can easily be replaced by removing the module cabling and undoing the corresponding module clamps. In this process, please observe the relevant safety requirements.

Maintenance log TopFix 200 & AeroFix

Commission:

Place:

Ok not Ok.

- | | | |
|--------------------------|--------------------------|--|
| <input type="checkbox"/> | <input type="checkbox"/> | The system is in a visually perfect condition and according to the installation plan in the correct position |
| <input type="checkbox"/> | <input type="checkbox"/> | Mounting system tested for stability and corrosion |
| <input type="checkbox"/> | <input type="checkbox"/> | No damage to the roof by the PV system |
| <input type="checkbox"/> | <input type="checkbox"/> | Mechanical connections for tight fit and tightening torque tested according the installation manual |

Zusätzlich nur bei AeroFix

- | | | |
|--------------------------|--------------------------|---|
| <input type="checkbox"/> | <input type="checkbox"/> | Building protection mats are in the correct position |
| <input type="checkbox"/> | <input type="checkbox"/> | Ballast is in the correct position (on the base rail or ballast rail) |
| <input type="checkbox"/> | <input type="checkbox"/> | Ballast is visually fine (no cracks, breaks etc.) |
| <input type="checkbox"/> | <input type="checkbox"/> | Unhindered water drainage |

Comments

.....
.....
.....
.....

Maintenance was carried out by

Company:.....

Person:

The maintenance work must be carried out by a technical company that has experience with electrical systems and works with the mounting systems.

The completed maintenance log must be handed over in copy to the plant operator.

I confirm the correctness and execution of the maintenance

Place, date

Signature

Need of the written form of an authorized person!

Printed Name



IBC SOLAR AG
Am Hochgericht 10
D-96231 Bad Staffelstein
Phone +49 (0) 9573-92 24 0
Fax +49 (0) 9573-92 24 111
info@ibc-solar.de
www.ibc-solar.com